

Collaborative Software Development

Michel Beaudouin-Lafon

Based on slides by Cédric Fleury revised by Anastasia Bezerianos

Université Paris-Saclay
mbl@lisn.fr

Software development

Several users working on a same project

- Remote or collocated users

- Each one works on their own computer (asynchronous)

 - on different tasks

 - at different times

Collaboration is hard to organize

- Versioning, synchronization between users

- Task distribution, social aspects

Outline

Collaborative software development

Version control

Continuous integration

Software development methods

Outline

Collaborative software development

Version control

Continuous integration

Software development methods

Why version control?

We want to avoid:

Manually sharing files (USB key, email, Dropbox)

Deleting or overwriting the files of other users

Breaking the project by making a mistake

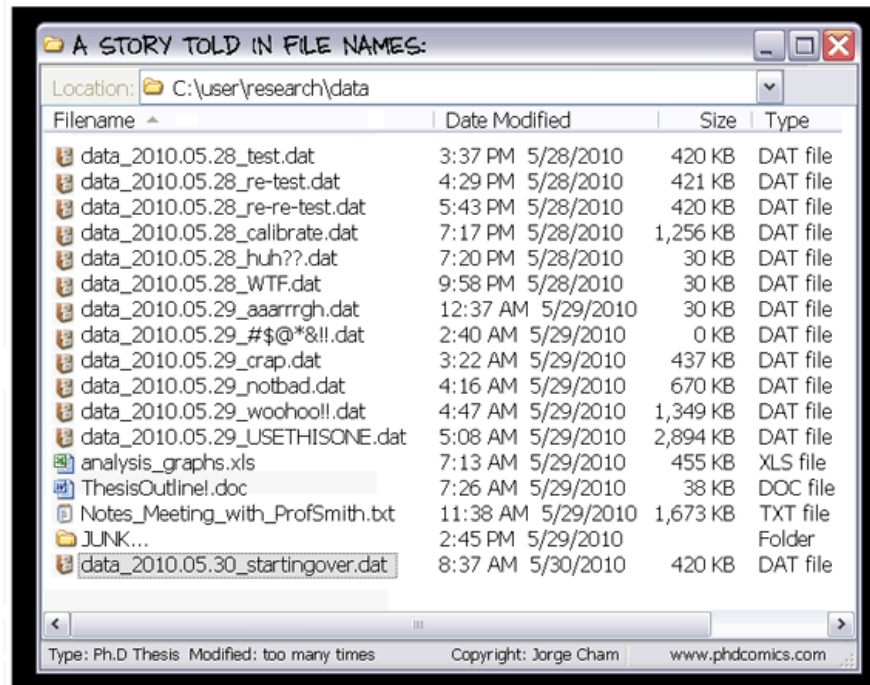

Why version control?

We want to be able to:

Edit the project at the same time, and merge our work

Keep an history of the modifications, restore old ones

Keep older versions of the files

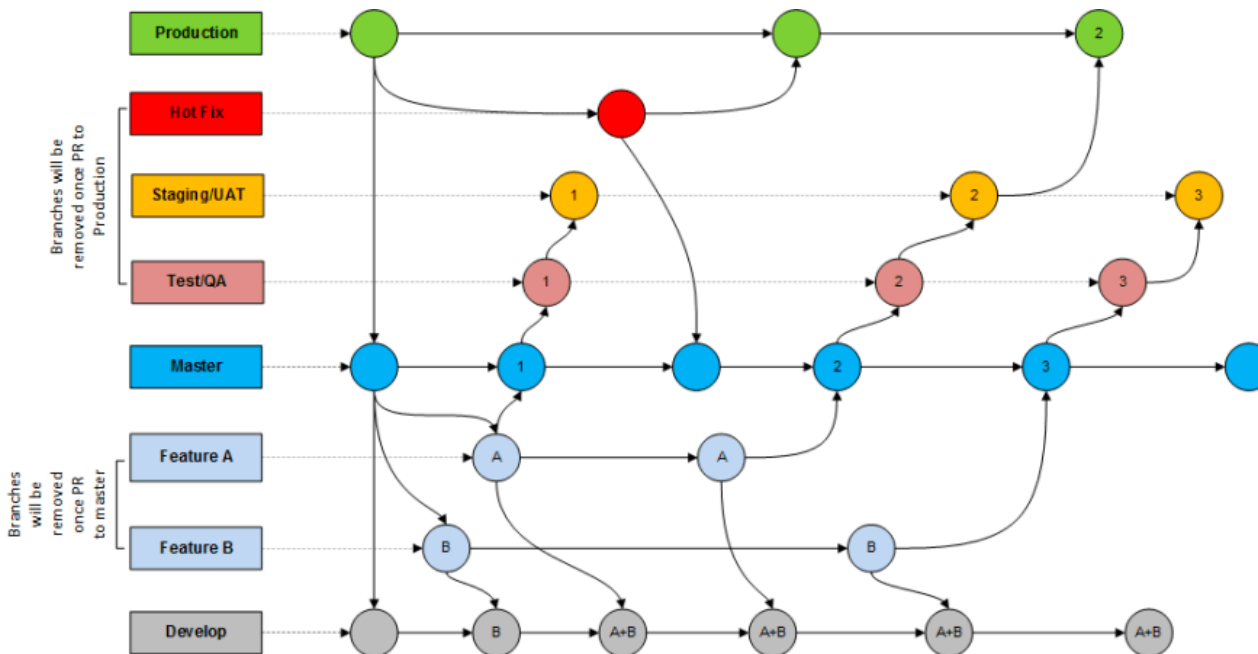



Version control software

Save & restore different *versions* of the files

Synchronize users' versions

Keep track of modifications and their authors

Manage *branching* and *merging*

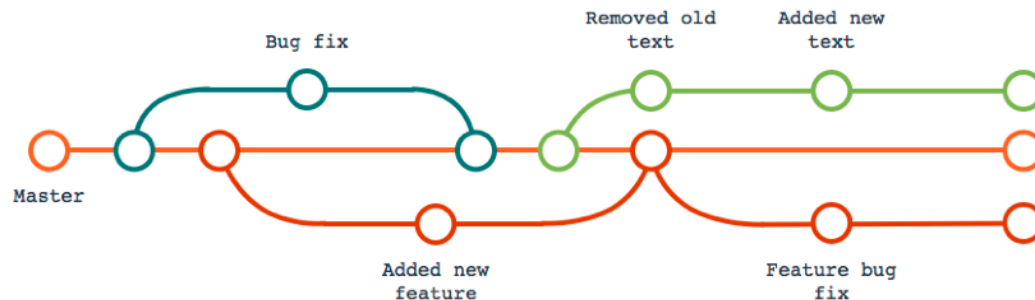

Not only for software development

Report, images, data from experiments

Basic version control actions

Create a repository

Create a local working copy

Add a file to the repository

Commit a change to the repository = create a new version

Update the local copy with the current state of the repository

Revert a file to a previous version

Show the history of a file

Show the differences between two versions

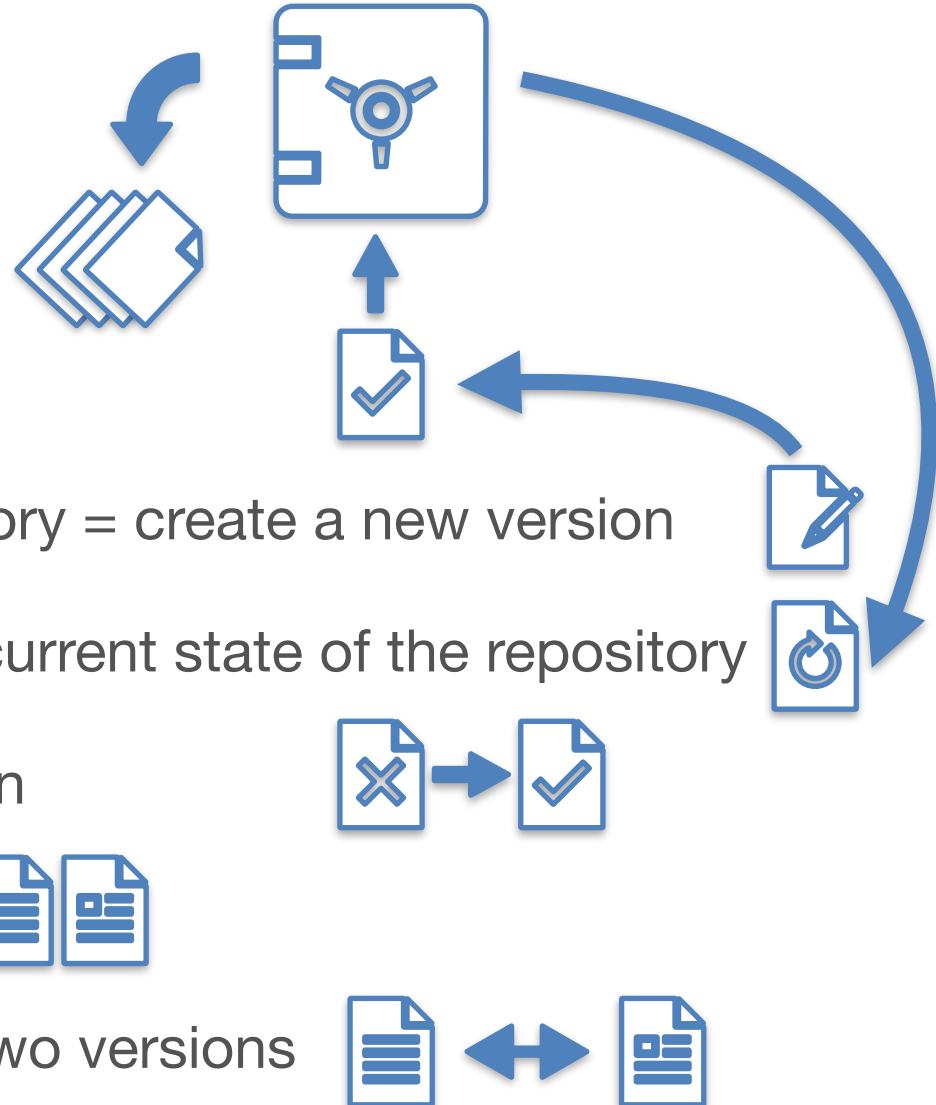

Version control software architectures

Centralized

CVS, **SVN**, TFVC, ...

Decentralized (peer-to-peer):

GNU Arch, Mercurial, Bazaar, **Git**,...

Decentralized can be used as a Hybrid Architecture

One peer can be a central server (github)

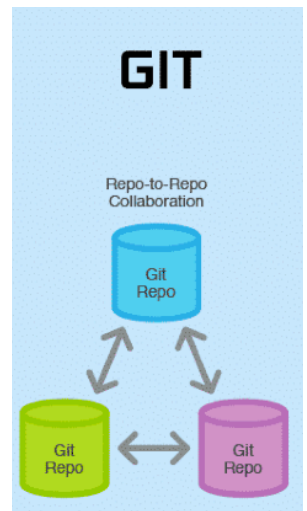
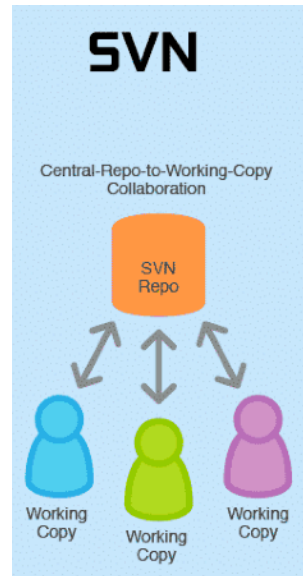

Centralized architecture

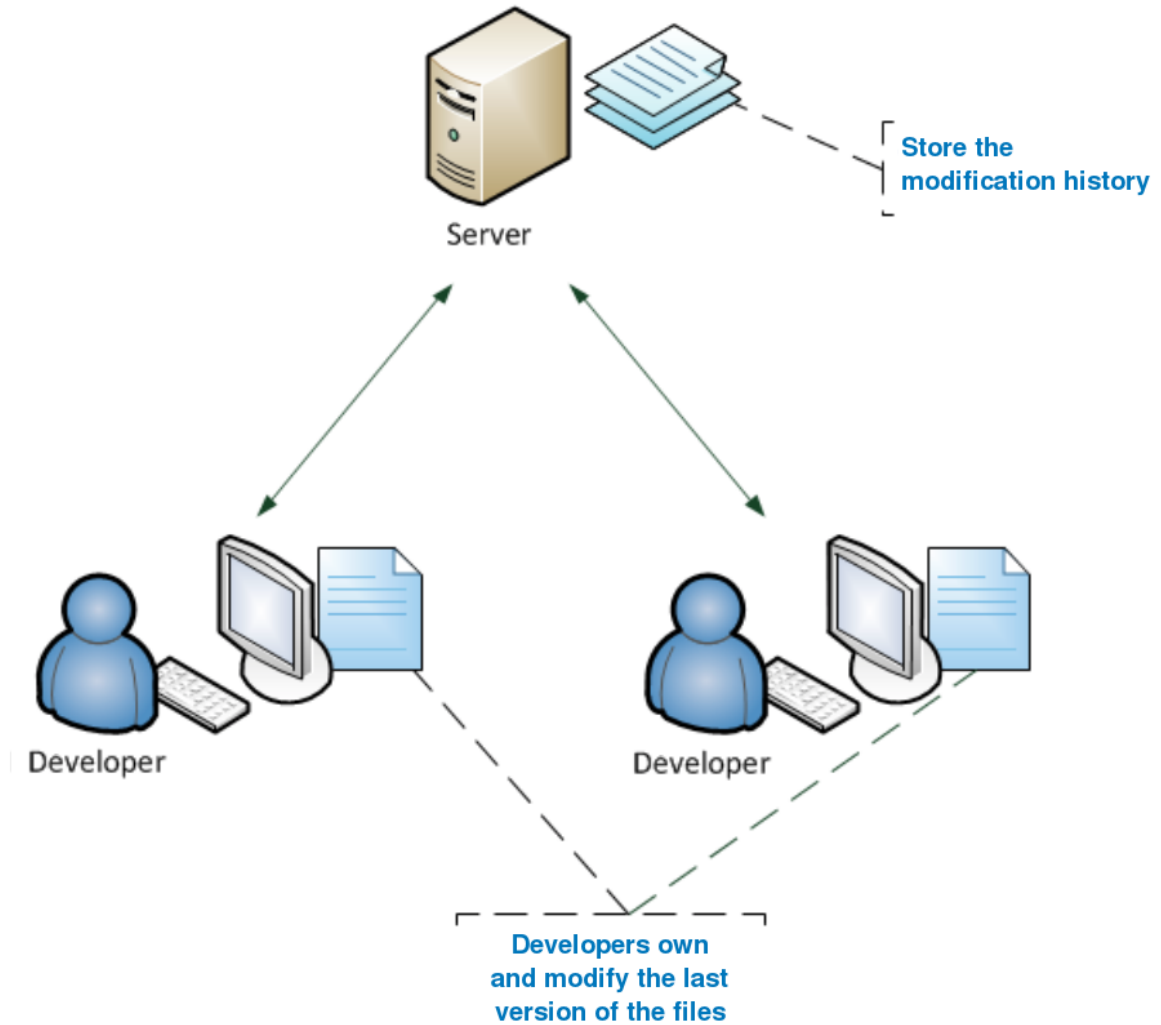

Drawbacks of centralized architecture

Single access point to the data

Single communication point between users

Single history / timeline of the files

Versioning and sharing are the same operation

Need to have a stable state before “committing” a change

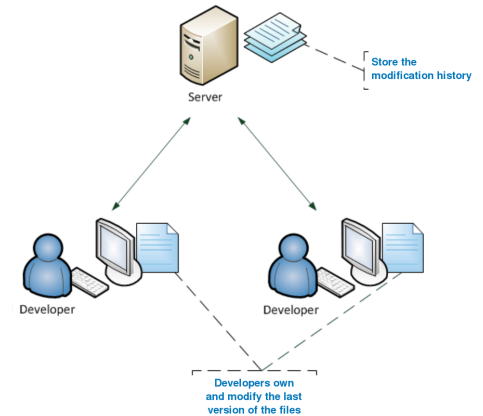

Decentralized architecture

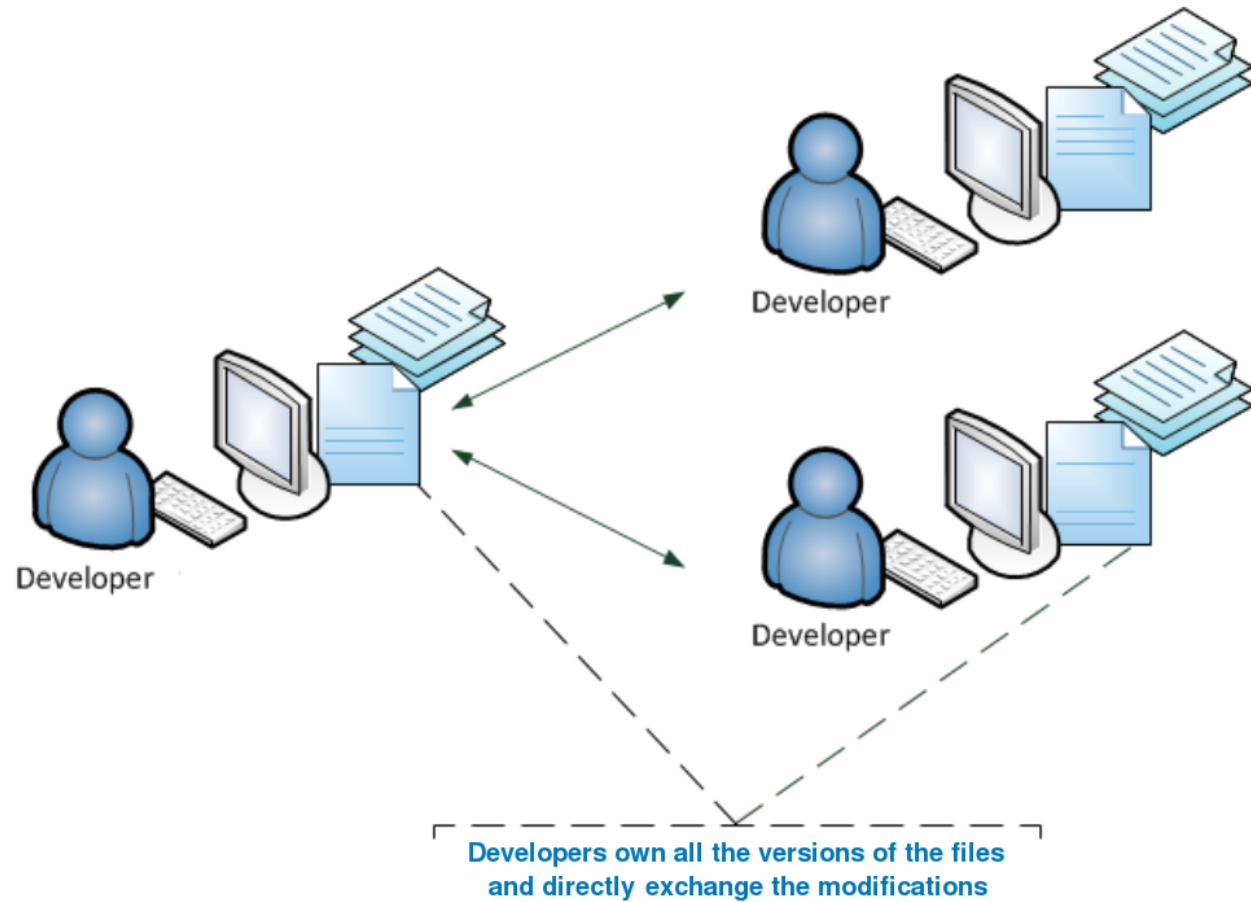

Hybrid architecture

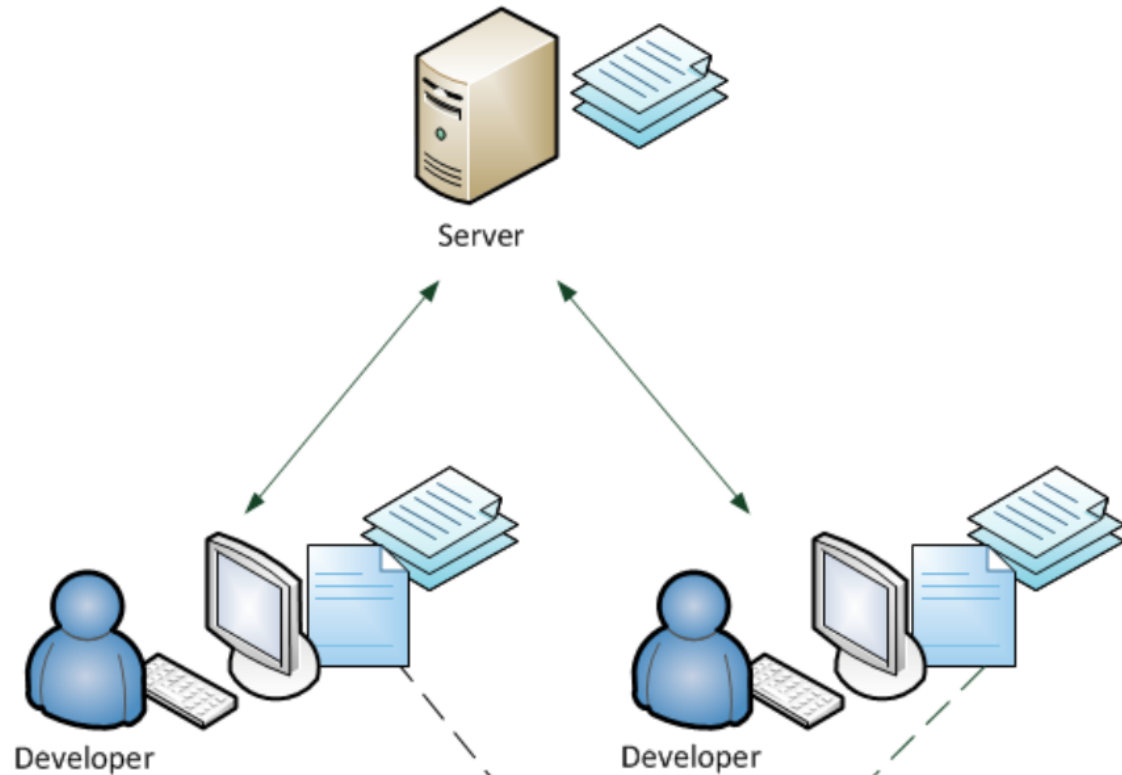

Developers own all the versions of the files and exchange modifications via the server

Vocabulary (SVN)

Architecture

Repository

Working copy

Actions

Checkout

Add

Commit

Update

Revert

Diff, log, status

Centralized Architecture

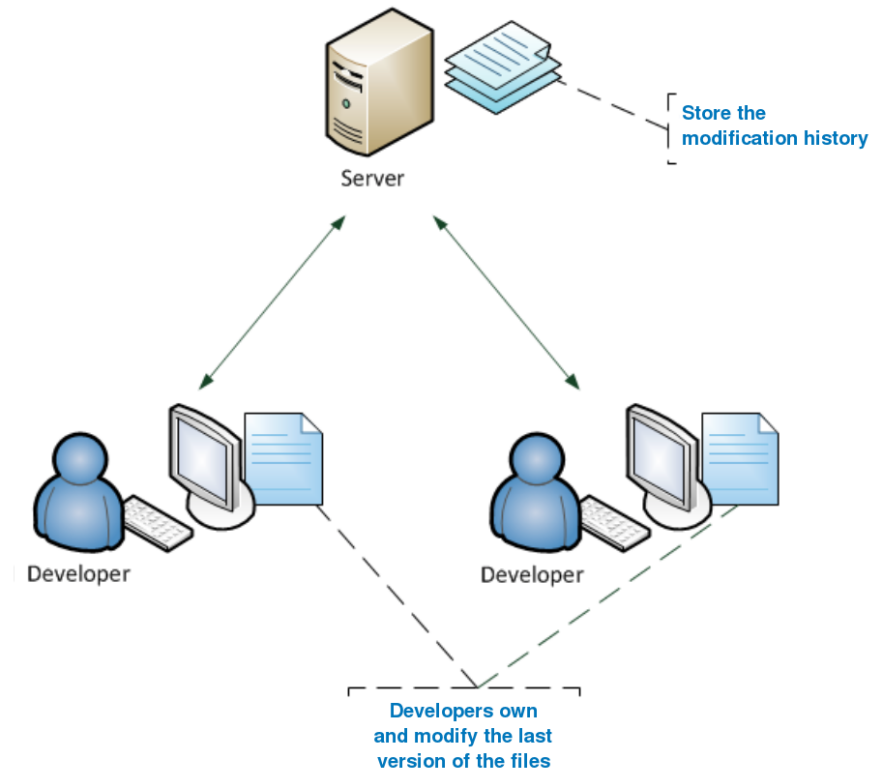

Vocabulary (git)

Architecture

Remote and local repository

Working copy

Actions

Clone

Add

Commit

Push / Pull

Reset

Diff, log, status

Hybrid Architecture

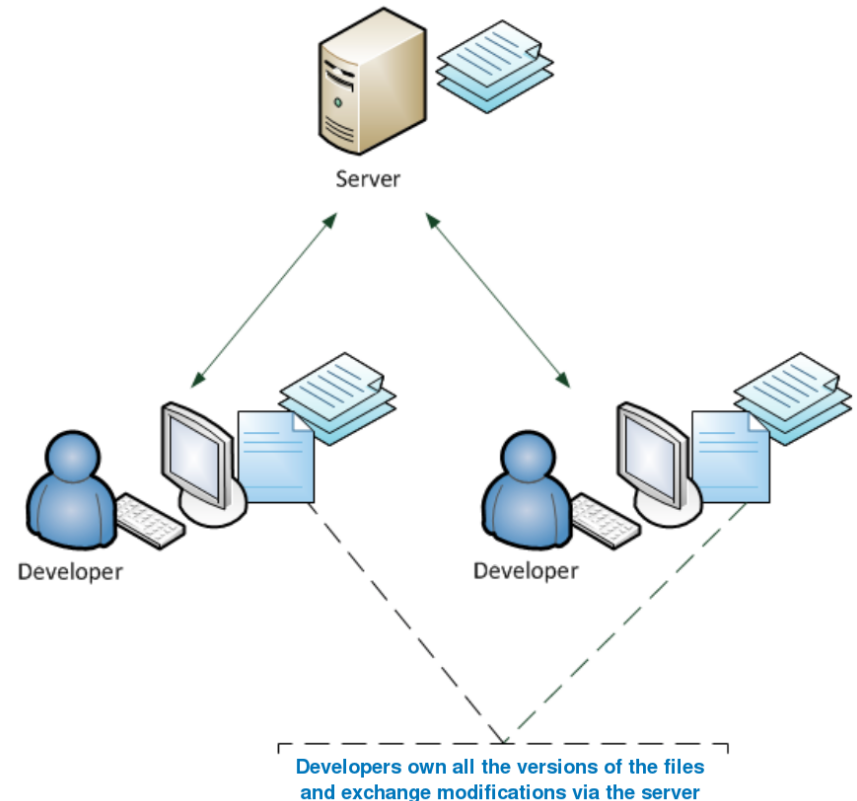

Good practices

Work on the local copy

Before sending a modification

- Check if the code compiles locally

- Check for updates from the other users

 - Manage conflicts if there are some

- Check if the code compiles with the updates

Commit the change to the repository

Conflict management

Multiple users can make changes to the same (text) file

If the changes do not overlap

=> the system merges the changes

If the changes do overlap

A conflict appears, to be resolved “by hand”

By telling to the system which version is correct

By merging the modifications of the users

Conflict management

```
C:\workspace\test>svn update
Conflict discovered in 'test.txt'.
Select: (p) postpone, (df) diff-full, (e) edit, (r) resolved,
        (mc) mine-conflict, (tc) theirs-conflict,
        (s) show all options: p
C      test.txt
Updated to revision 3.
Summary of conflicts:
  Text conflicts: 1
```

```
08/10/2010  11:44 AM          94 test.txt
08/10/2010  11:44 AM          26 test.txt.mine
08/10/2010  11:44 AM          27 test.txt.r2
08/10/2010  11:44 AM          31 test.txt.r3
```

test.txt

```
<<<<<<< .mine
test User2 making conflict
=====
User1 am making a conflict test
>>>>>>> .r3
```

Version control

Tools for conflict management (SmartGit)

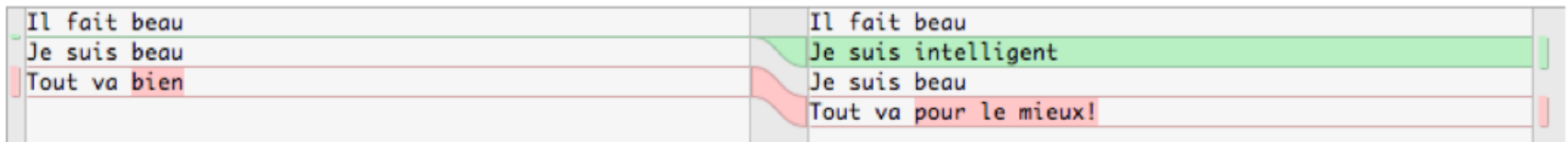
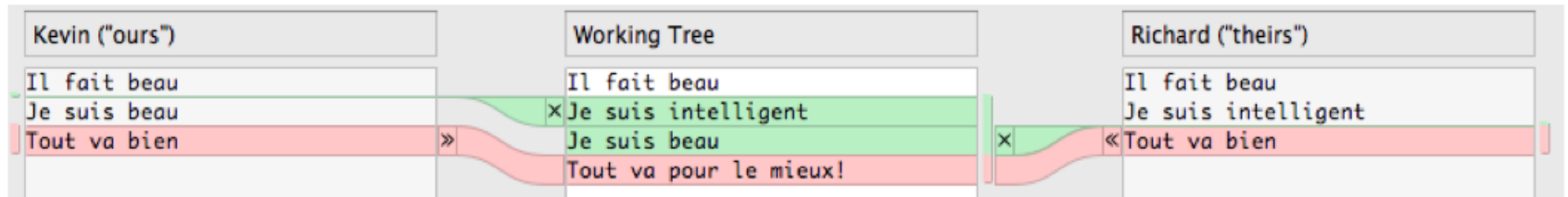

Three-way merge

The screenshot displays the SmartSynchronize 3.4.12 (3-Way Merge) interface. It shows three side-by-side code editors representing different versions of the `SdPrivateKeyCredential` class:

- Left Editor:** `C:\temp\a\SdPrivateKeyCredential-master.java`. Contains the master version of the code.
- Middle Editor:** `C:\temp\a\SdPrivateKeyCredential-common.java`. Contains the common ancestor code.
- Right Editor:** `C:\temp\a\SdPrivateKeyCredential-branch.java`. Contains the code from a branch.

The interface includes a menu bar (File, Edit, View, Go To, Window, Help) and a toolbar with actions like Save All, Reload, Prev. Change, Next Change, Take Left, Take Right, Left + Merge, All, Merge + Right, and Merge Below. The code is color-coded to show changes: red for deletions, green for additions, and blue for modifications. Colored arrows (red, green, blue) connect lines of code between the editors, illustrating the merge process. For example, a red arrow points from a line in the master editor to a corresponding line in the common editor, while a green arrow points from a line in the common editor to a line in the branch editor. The status bar at the bottom left shows "Ready".

Collaboration scenario: centralized (SVN)

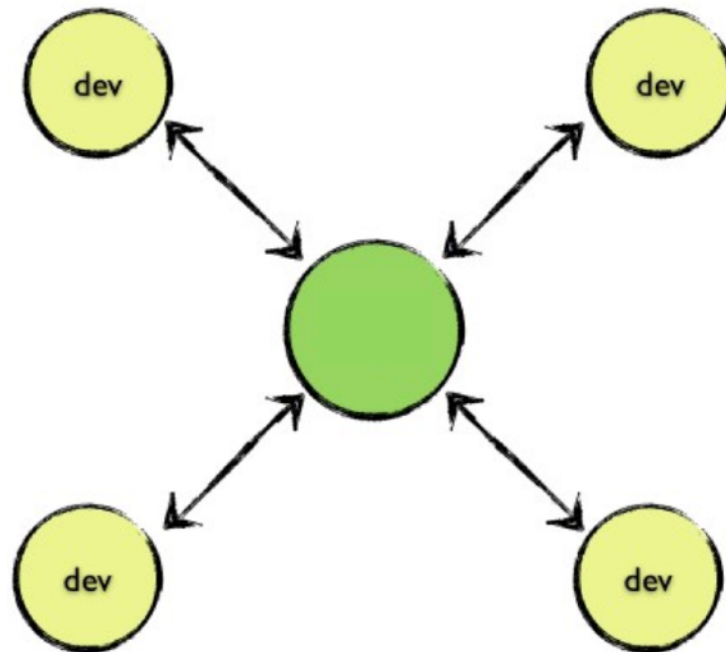

Collaboration scenario: decentralized (Git)

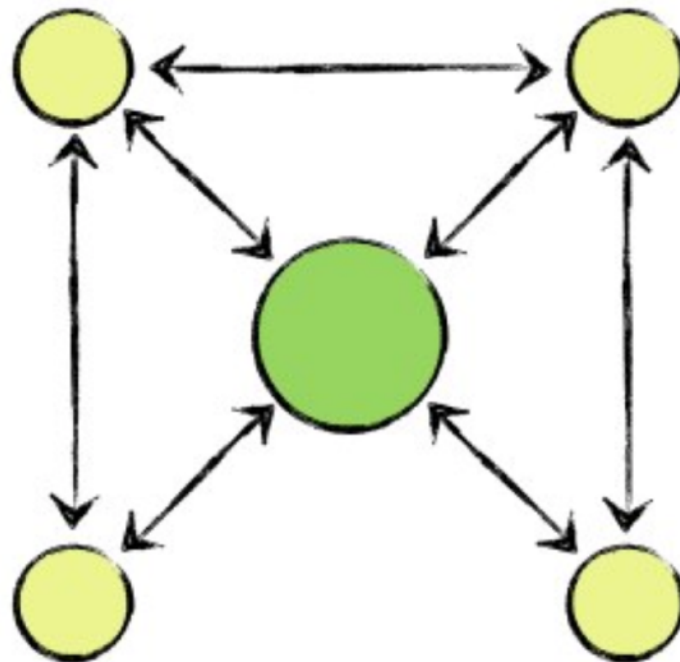

Inter-personal communications

Collaboration scenario: decentralized (Git)

Integration mode

A repository is in charge of the test

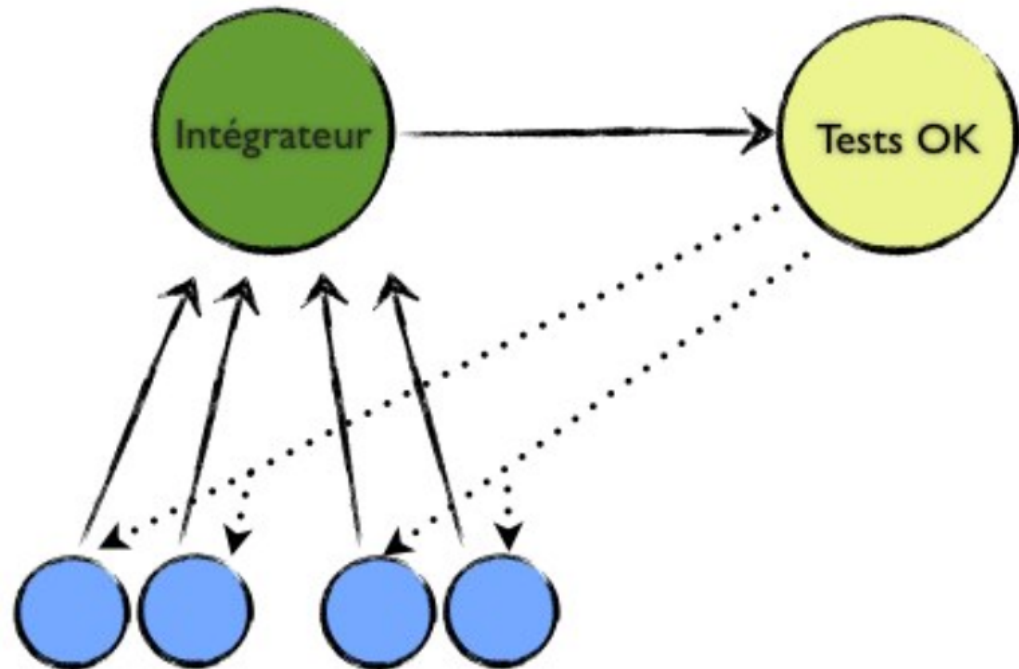

Collaboration scenario: decentralized (Git)

Dictator mode

Open-source projects

"Lieutenants" make a first check
before sending to the "dictator"

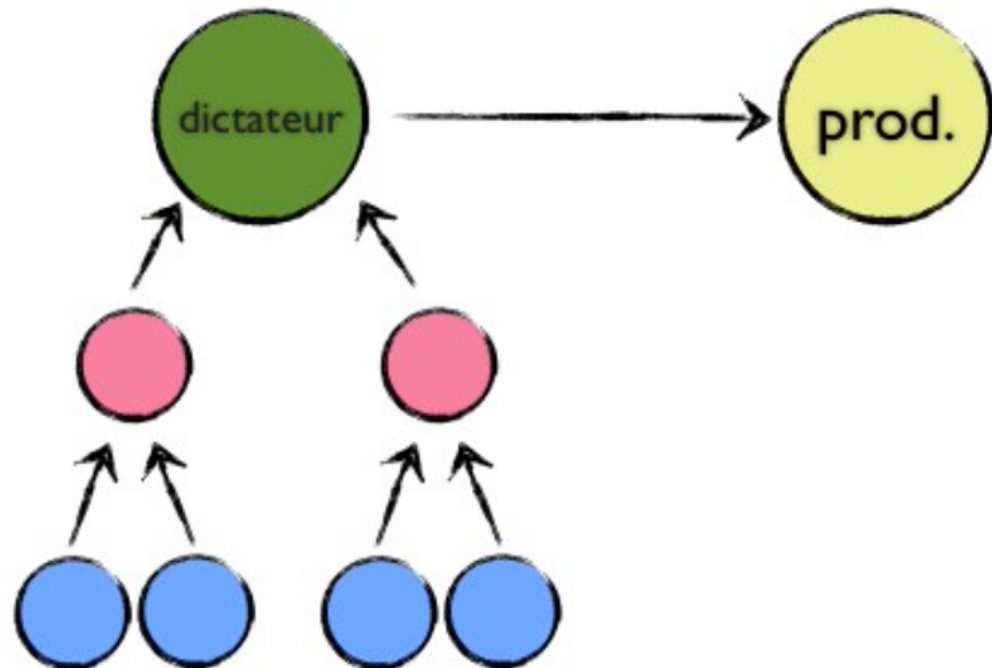

Collaboration scenario: decentralized (Git)

Multi-location teams

Each team can work independently

Regular integration of the work of each team

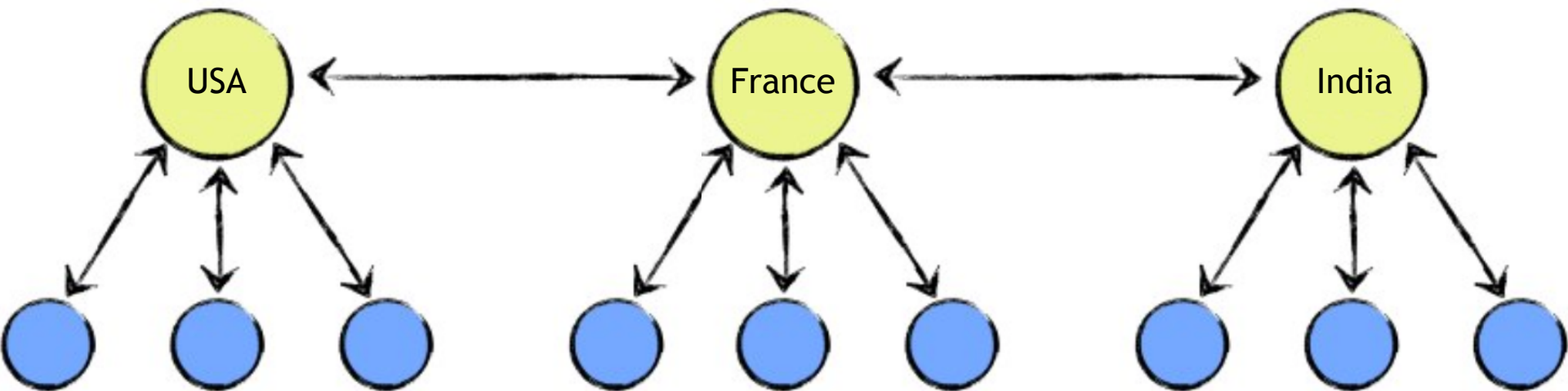

History management

The repository stores differences between text files

Computation of the history is linear
when considering the order of “commits”

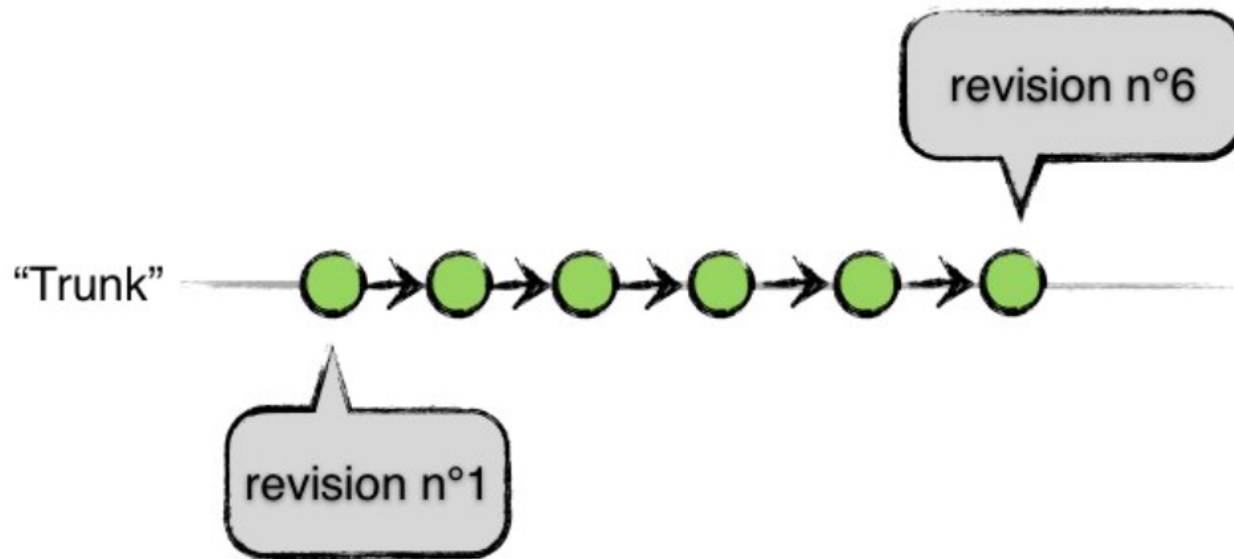

History management

SVN assigns a revision number to the entire project

Git assigns a revision number per file

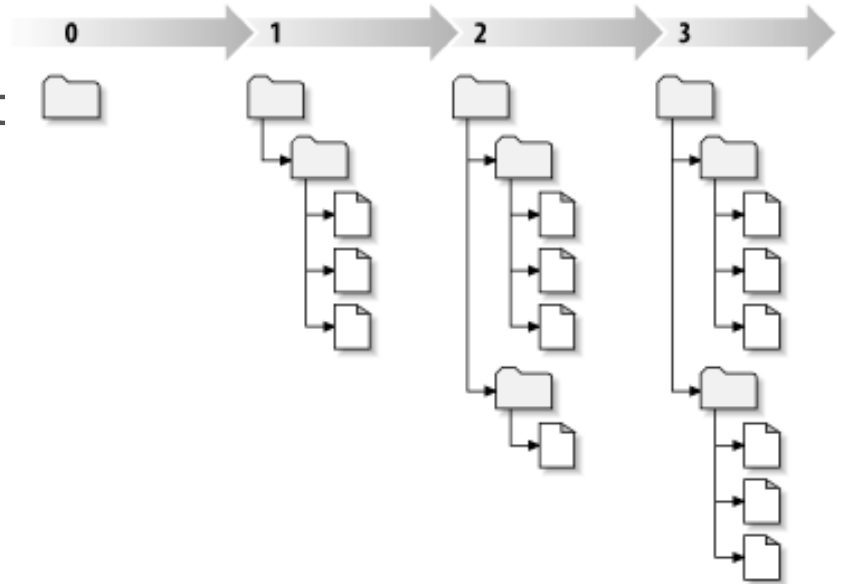

This difference impacts collaboration

Using branch for collaboration is easier with Git

Branch management

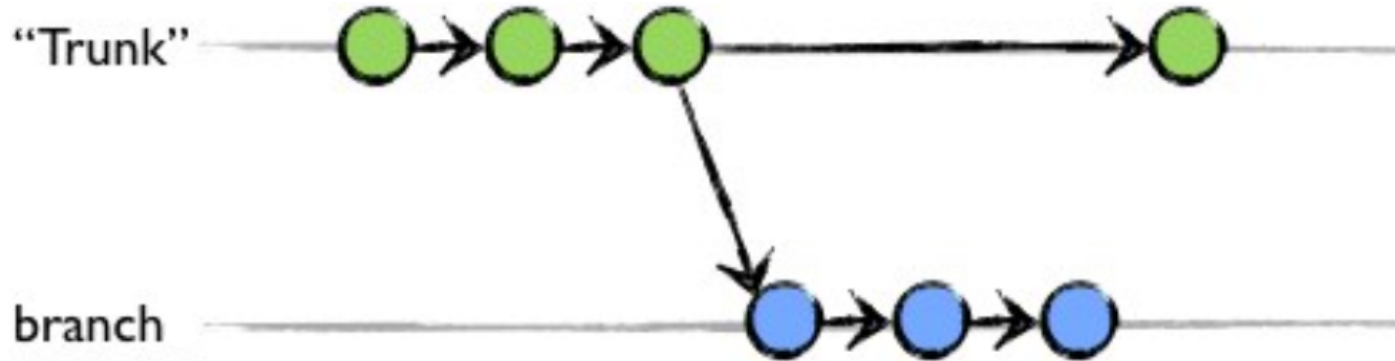

SVN makes a copy of the entire repository

Git makes a link to a particular state of the files

Branch management

Merging branch (very complex to achieve with SVN)

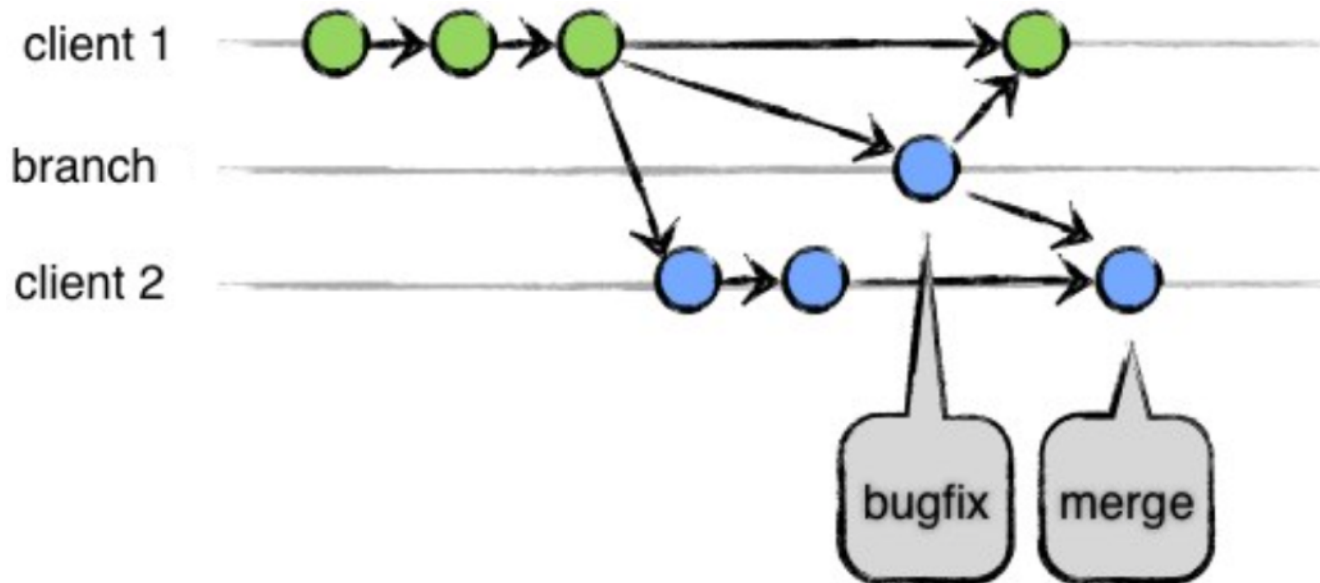

Branch management

Classical organisation of a project into branches

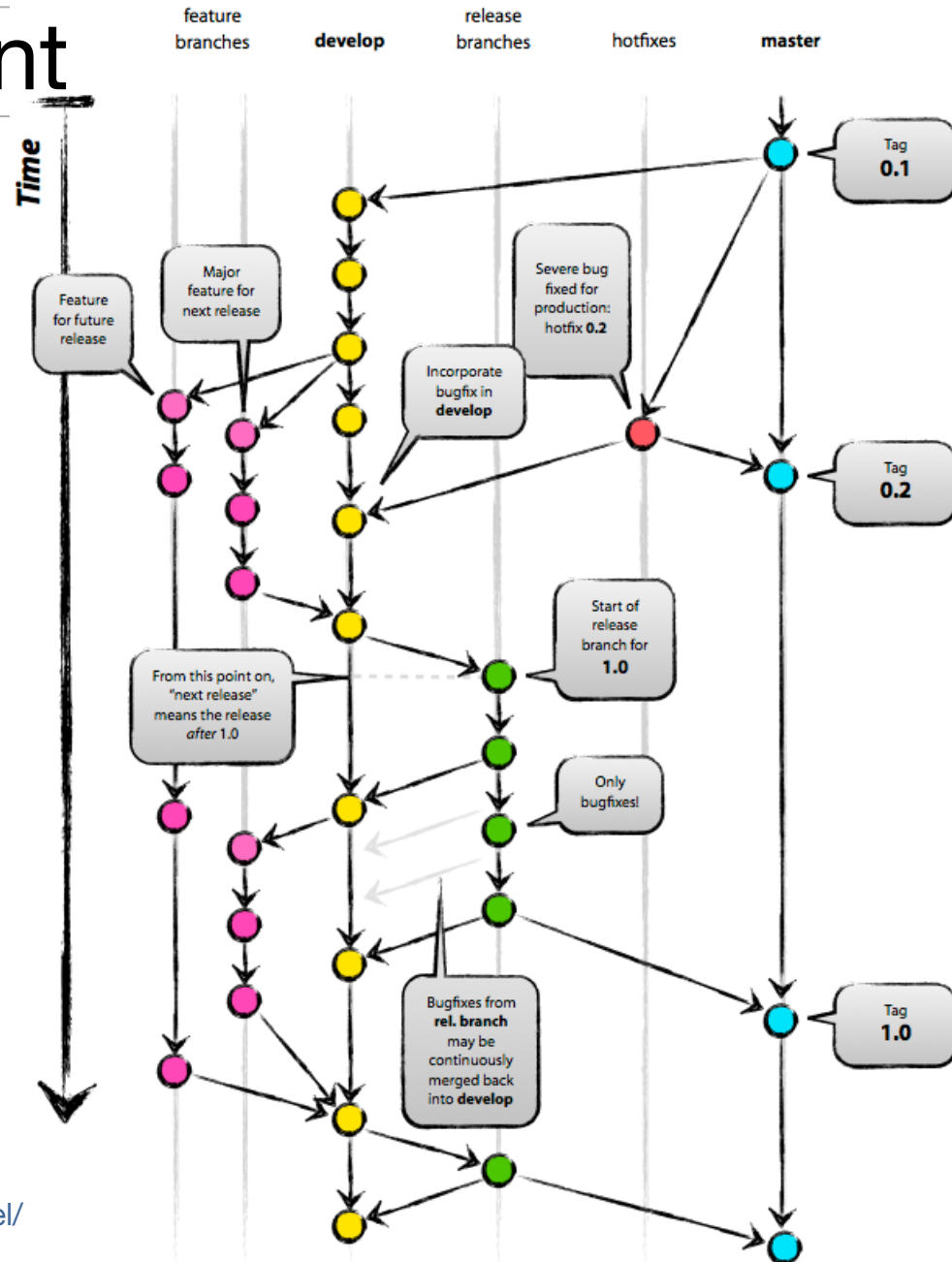

Branch management

Each user can work on a particular branch (or branches)

Branches can be synchronized between users

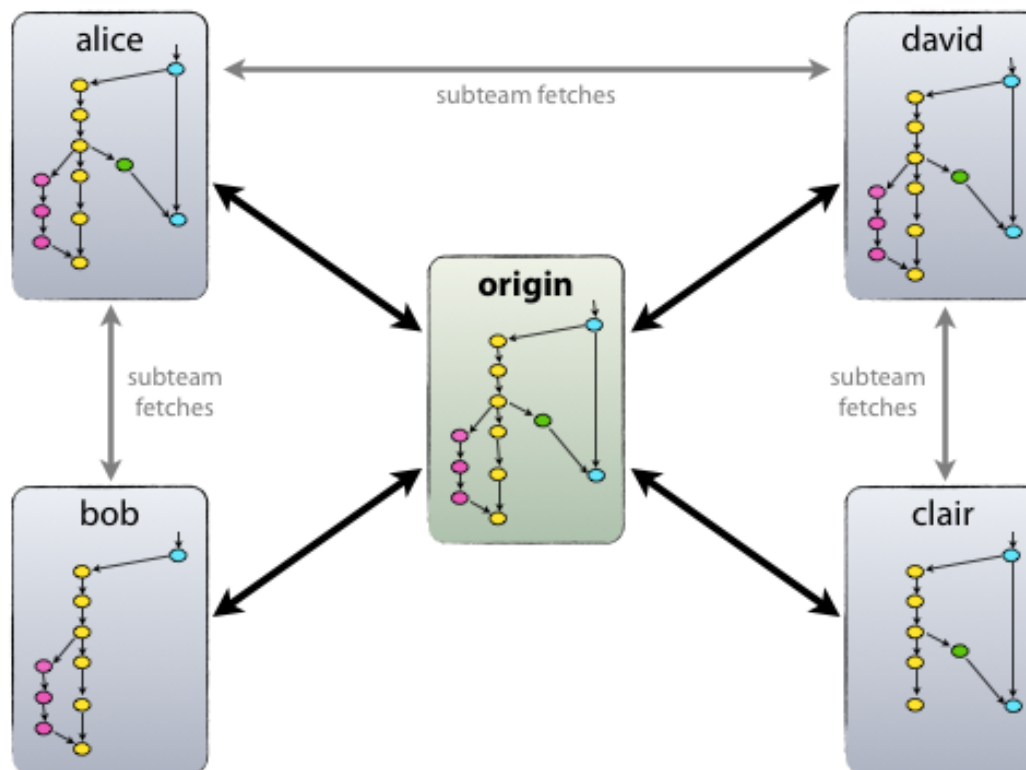

Web-based interfaces

Manage user access rights

Manage branches and access to branches

Review modifications and different versions

Track bugs

Create wiki / web pages for projects

Social networking



GitHub

Outline

Collaborative software development

Version control

Continuous integration

Software development methods

Continuous integration

Integration

Continuous merging & testing the work of several developers

Automatic deployment

System always running

Goals

Test modifications from the beginning

Detect integration problems at an early stage

Always have the system running

Tests, demos, discussion with the customers

Principles of continuous integration

Version control in a repository

Automatic and fast build

Auto-testing

"Commit" every day

Deployment on an integration computer after each "commit"

Automatic deployment

Executable always available

Everybody knows the build state

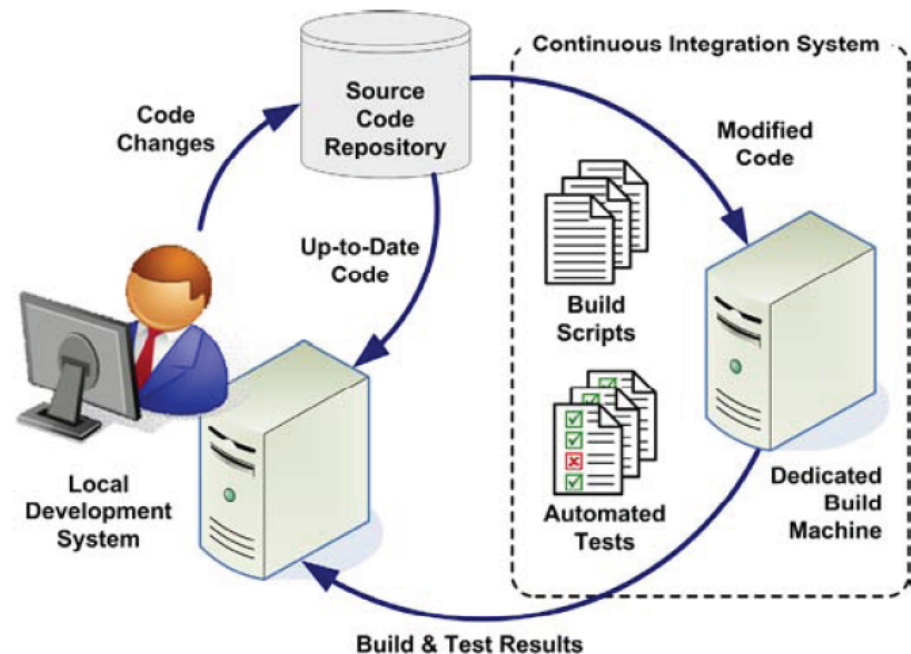

Feedback for collaboration (awareness)

Token on the desk of the person who builds

Make a sound when a build is valid

Web page of the integration server

Bubble light

Wallboard

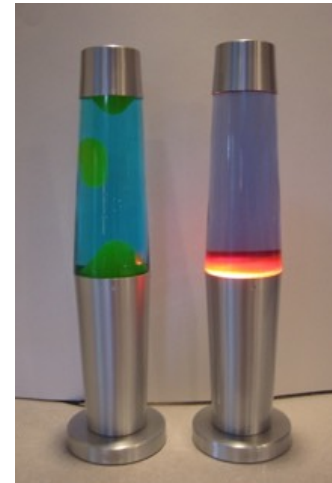

Outline

Collaborative software development

Version control

Continuous integration

Software development methods

Methods for software development

No methods: “Code and fix”

Efficient for small projects

Difficult to add new features or to find bugs

Engineering / plan-driven methodologies

Comes from civil or mechanical engineering

Drawing / construction plan / task distribution / construction

Agile methodologies

Adaptive rather than predictive

People-oriented rather than process-oriented

Classic methodology: the waterfall

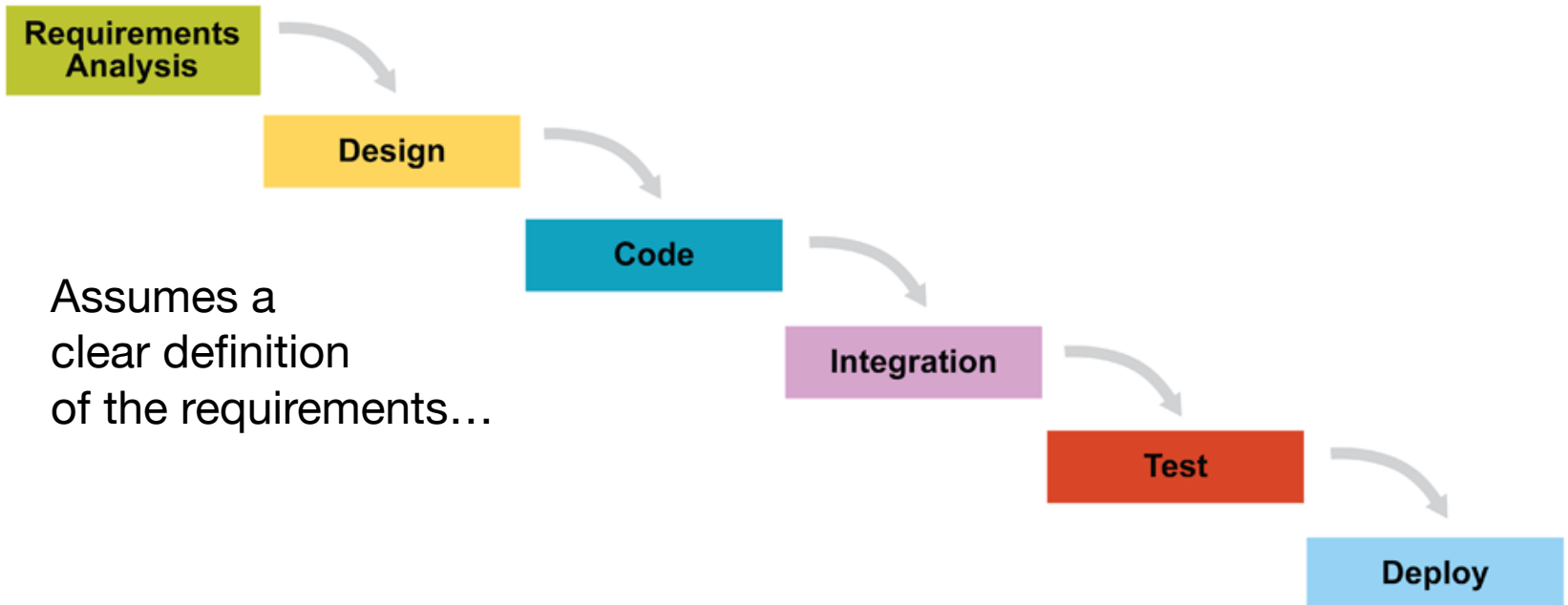

Assumes a clear definition of the requirements...

... and a clear ending

Predictability

Is software development end-result predictable?

Yes in some cases...

NASA programs (maybe)

Usually, requirements are unpredictable

(especially for software involving interaction with users)

Users / customers don't precisely know what they want

Hard to evaluate the cost of different options

Hard to estimate which features are useful

⇒ Requirements should be flexible

Agile manifesto

Manifesto for Agile Software Development

Individuals and interactions over processes and tools

Working software over comprehensive documentation

Customer collaboration over contract negotiation

Responding to change over following plan

<http://agilemanifesto.org>

Agile methods

Deal with unpredictable requirements

Iterative development

Involve the customers at each iteration

Improve the team organization (self-adaptive process)

Effective team of developers (people first)

Do not consider developers as replaceable parts

Analysts, coders, testers, managers

Developers are professionals who

make the technical decisions

evaluate the time required to perform the tasks

Agile methods

Examples

XP (Extreme Programming)

Test-driven development, **pair programming**

Scrum

Crystal

Safety, efficiency, habitability (less disciplined than XP)

Open source process

Distributed contributors, parallelized debugging

Lean software development (Lean development @ Toyota)

Just in time, Jidoka ("automation with a human touch")

RUP (Rational Unified Process)

Use case driven, iterative, architecture centric

Pair/peer programming

Two programmers

One computer

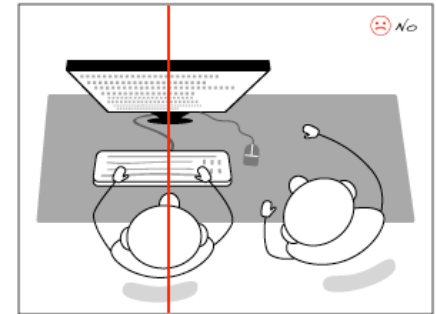
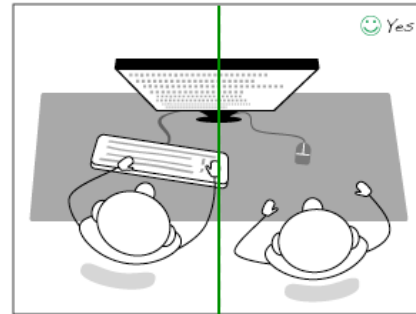

Roles

Driver: operates mouse and keyboard

Code: syntax, semantics, algorithm

Navigator: watches, learns, asks, talks, makes suggestions

Higher level of abstraction

Test, technical task, time since the last commit,

Quality of the overall design

Pair/peer programming

Advantages

Code quality

Better designs, Fewer bugs

Productivity

May be lower in short term, but higher in long term

Spreading Knowledge

Pairs have to switch regularly

Technical and conceptual knowledge

Social aspects

No loneliness, conviviality, better motivation

Scrum

Iterations called Sprints (about 1 month)

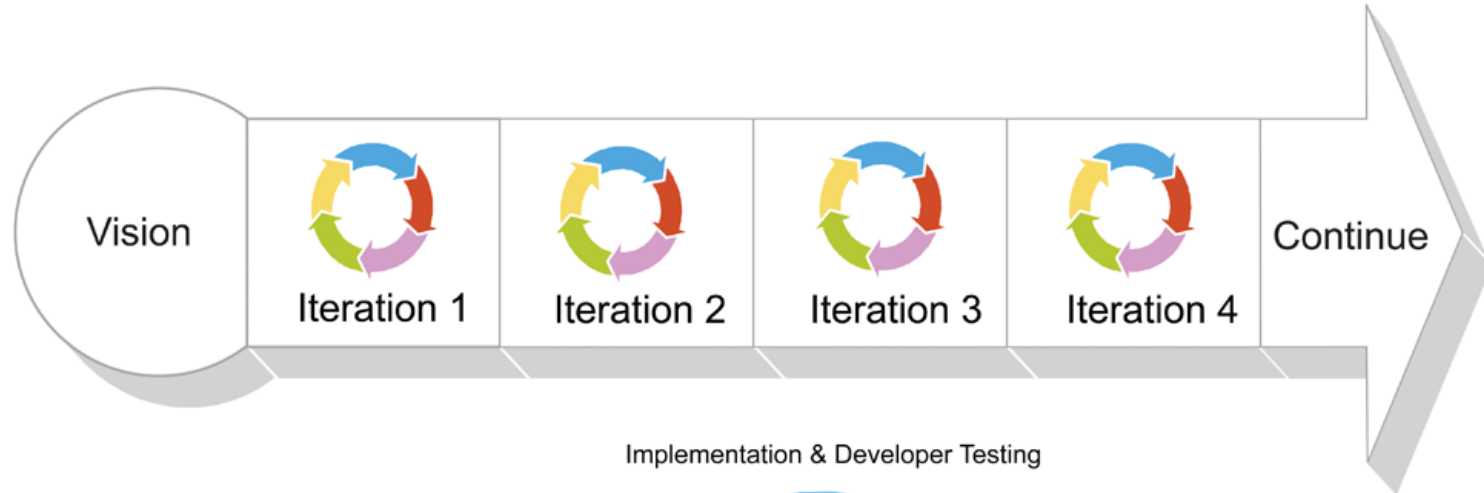

Iteration Detail

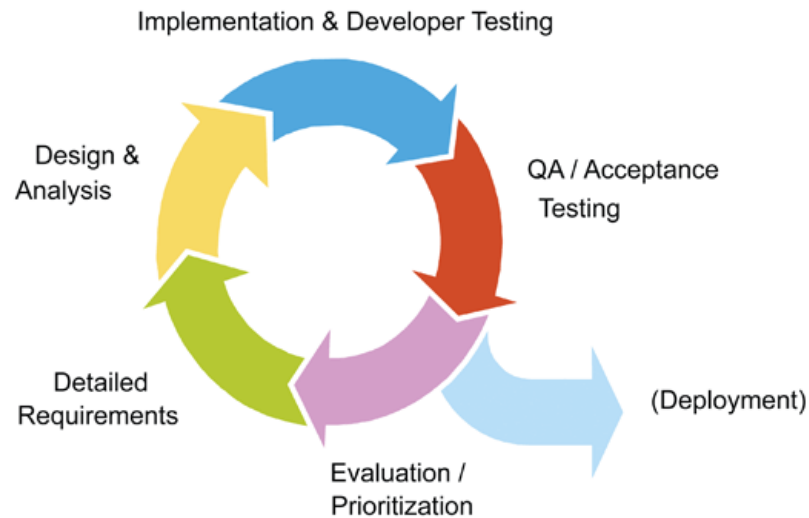

Scrum: roles

Product Owner (one person)

Responsible for products vision

Constantly re-prioritizes the Product Backlog

Accepts or rejects product increment



Development team

Self-organized

Negotiates commitments with the Product Owner

Has autonomy regarding how to reach commitments

Intensely collaborative



Master

Facilitates the Scrum process

Helps resolve issues

Shields the team from external inferences and distractions

Has no management authority



Scrum: product backlog

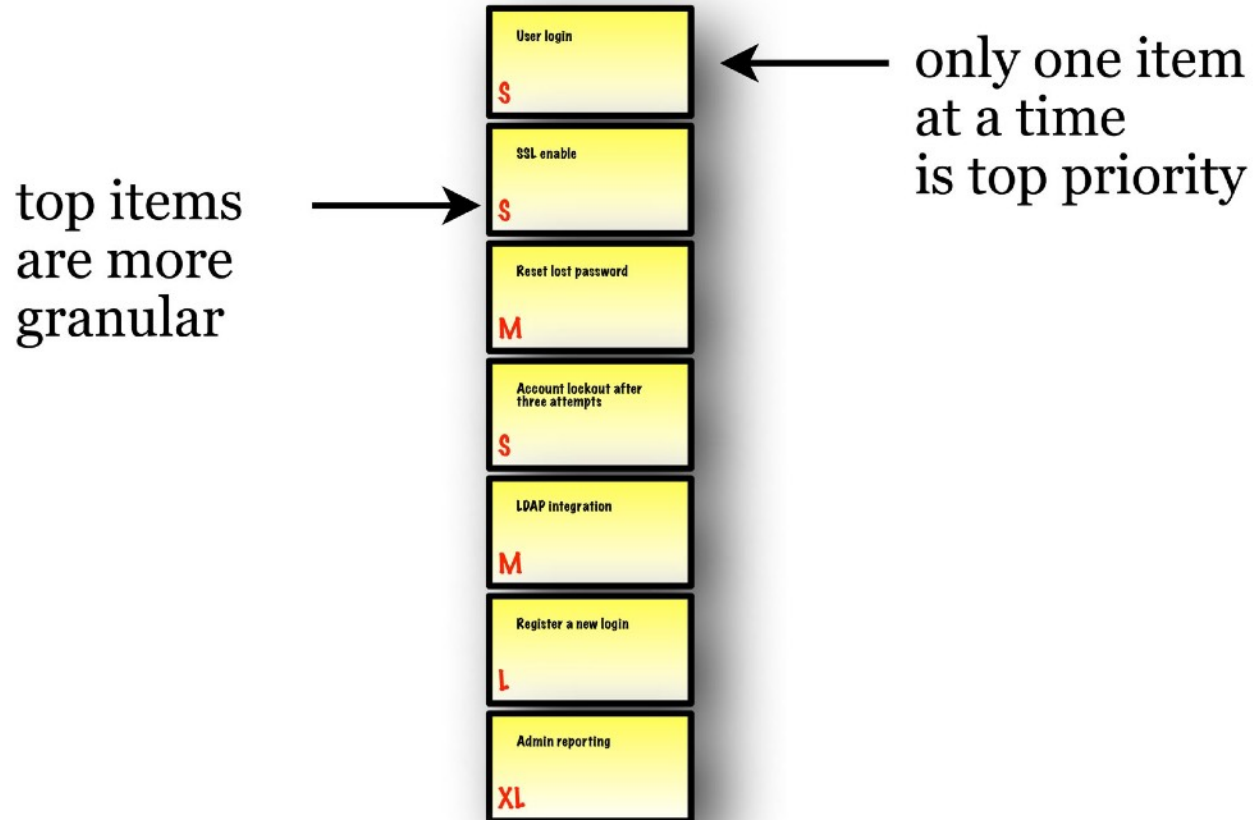

Sprint planning

Planning Meeting

Negotiate which Product Backlog items will be processed

Break items into a list of sprint tasks

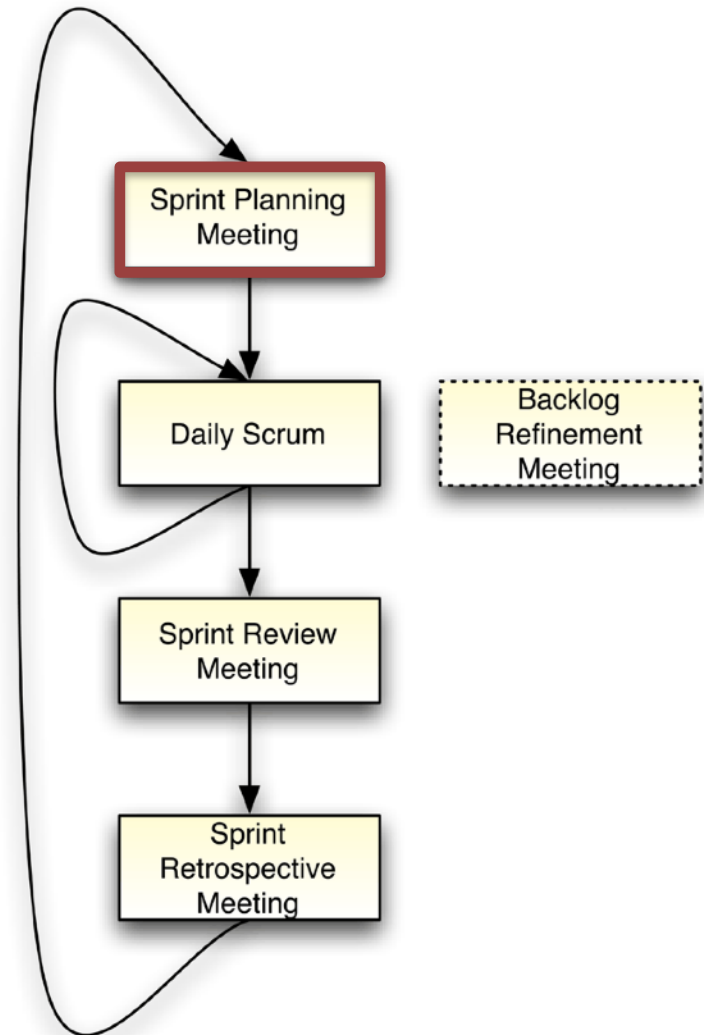

Sprint backlog

Product Backlog

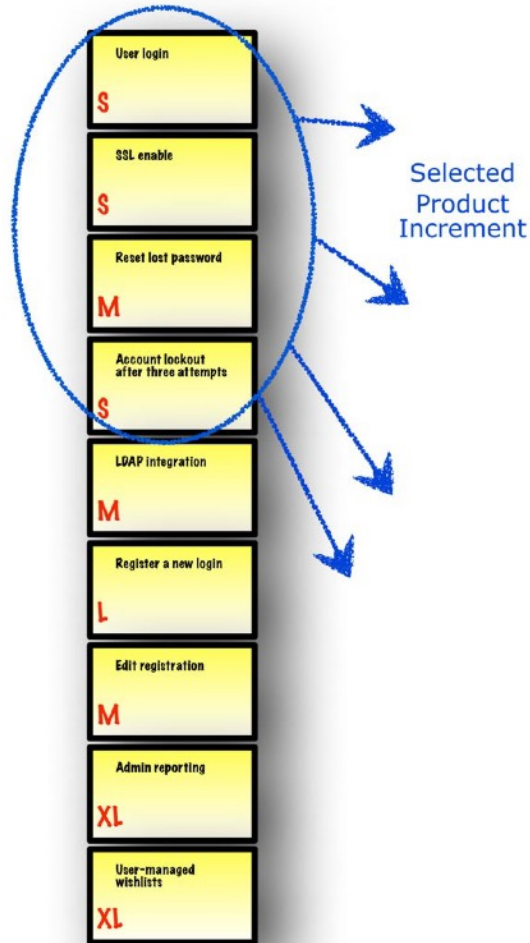

Sprint Backlog

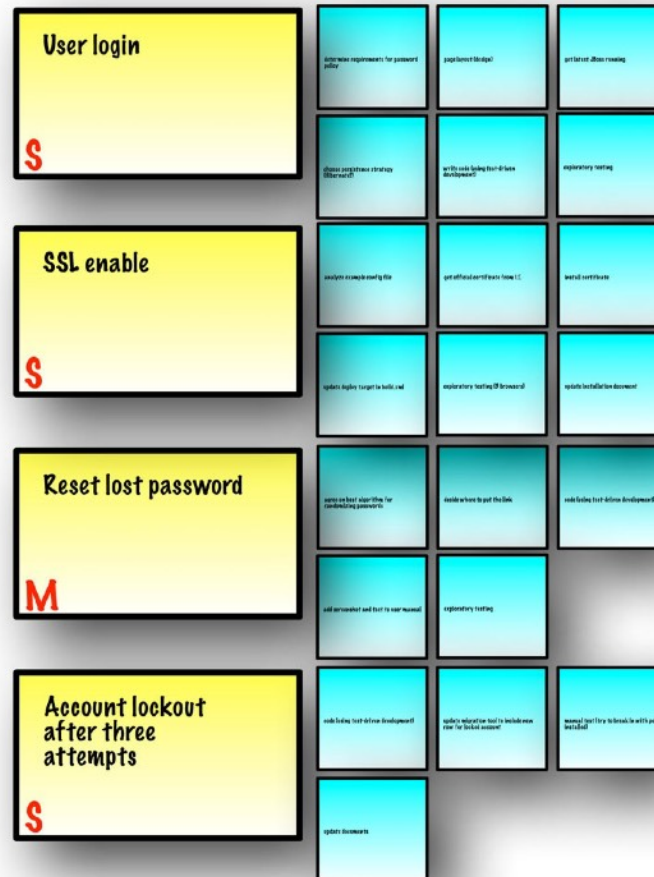

Daily scrum

Planning Meeting

Daily Meeting

Same time and place

15 minutes, standing up







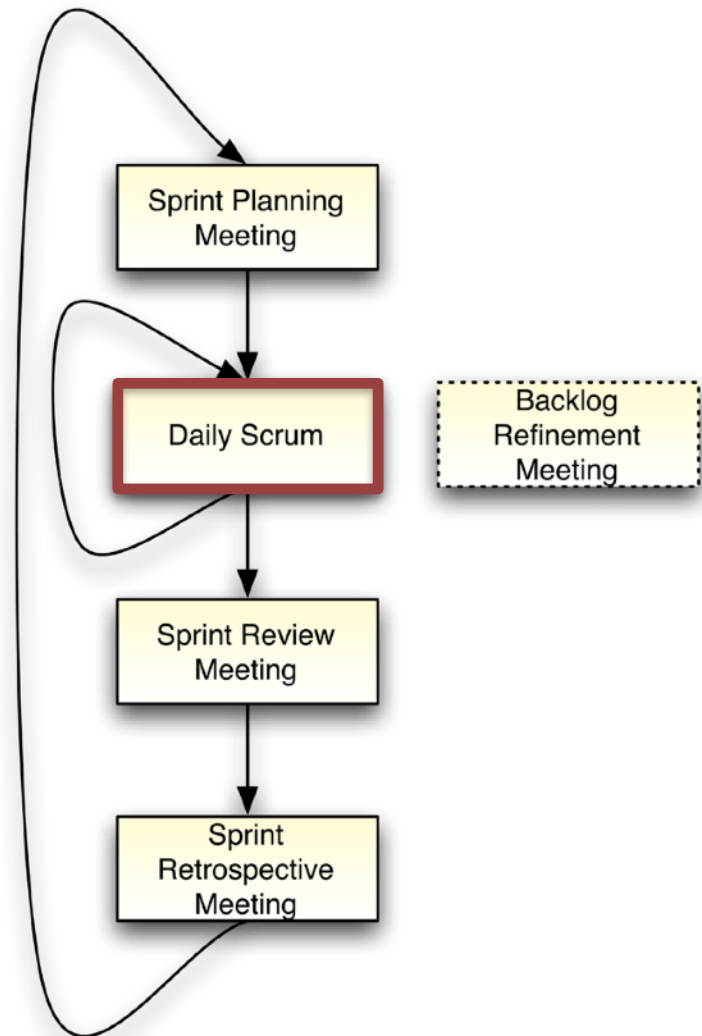













Summarize work of previous day,
work of today, issues

Maintain tasks list
(not started, in progress, done),
issues list and burn-down chart

Product Owner may attend



Sprint backlog

Committed Backlog Items	Tasks Not Started	Tasks In Progress	Tasks Completed
	  		 
	  		
	     		
			

Sprint review

Planning Meeting

Daily Meeting

Review Meeting

Demonstrate the working product increment to the Product Owner

Product Owner declares which items are done

Unfinished items return to the Product Backlog

Master proposes new items for the Product Backlog

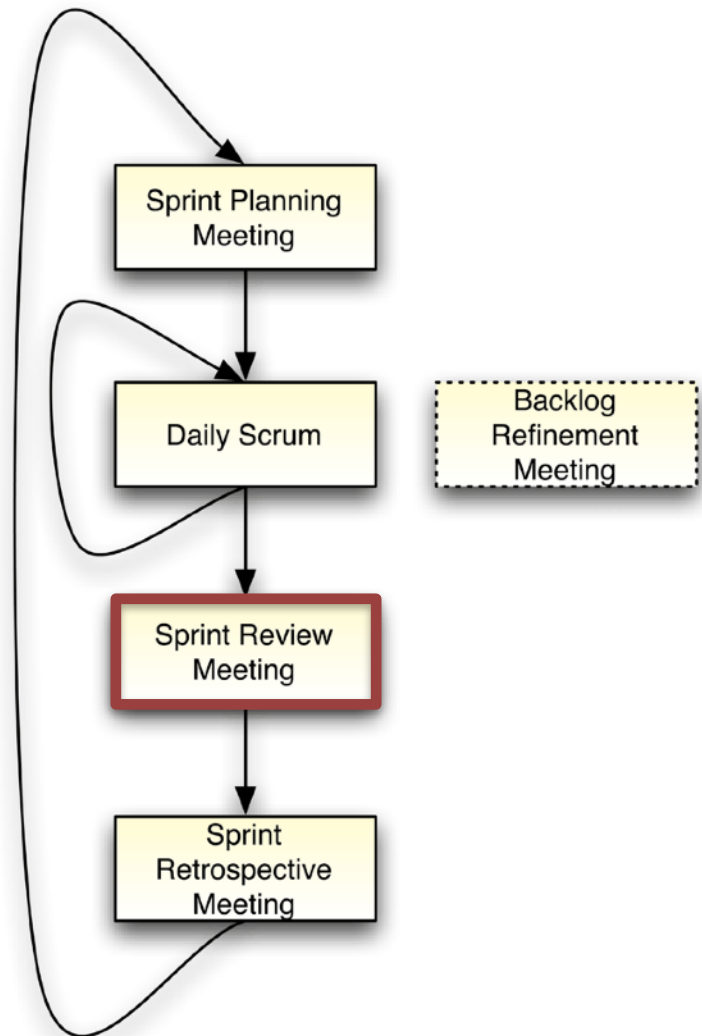

Sprint retrospective

Planning Meeting

Daily Meeting

Review Meeting

Retrospective Meeting

Team reviews its own process

Team adapts it for future Sprints

Master has to manage
the psychological aspects
of the meetings

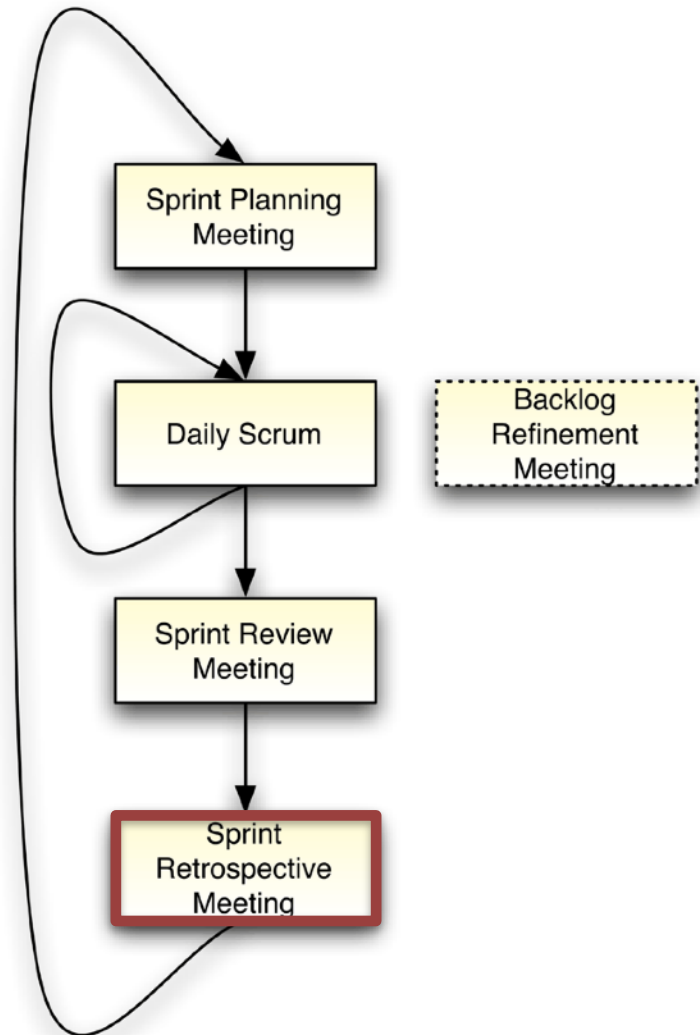

Backlog refinement

Planning Meeting

Daily Meeting

Review Meeting

Retrospective Meeting

Backlog Refinement Meeting

Items are usually too large
or poorly understood

Refine items into smaller ones

Master can help

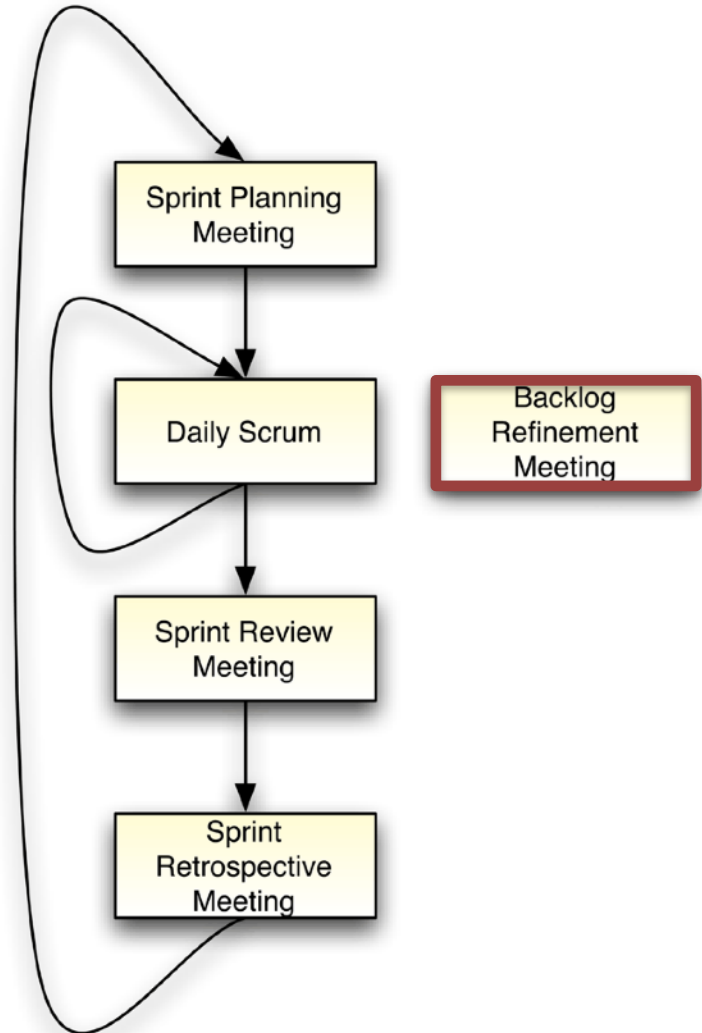

Wallboard

Feedback to the team

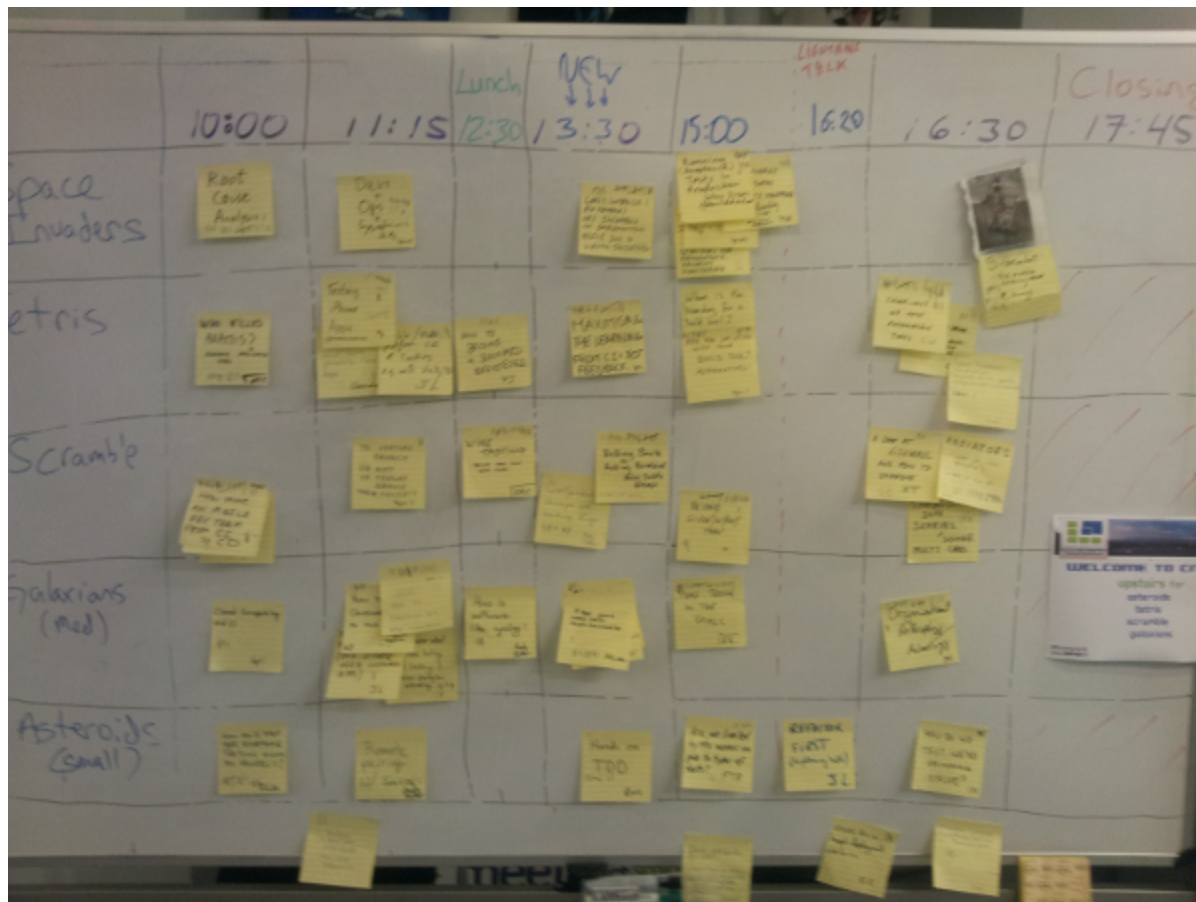

Wallboard

Feedback to the team

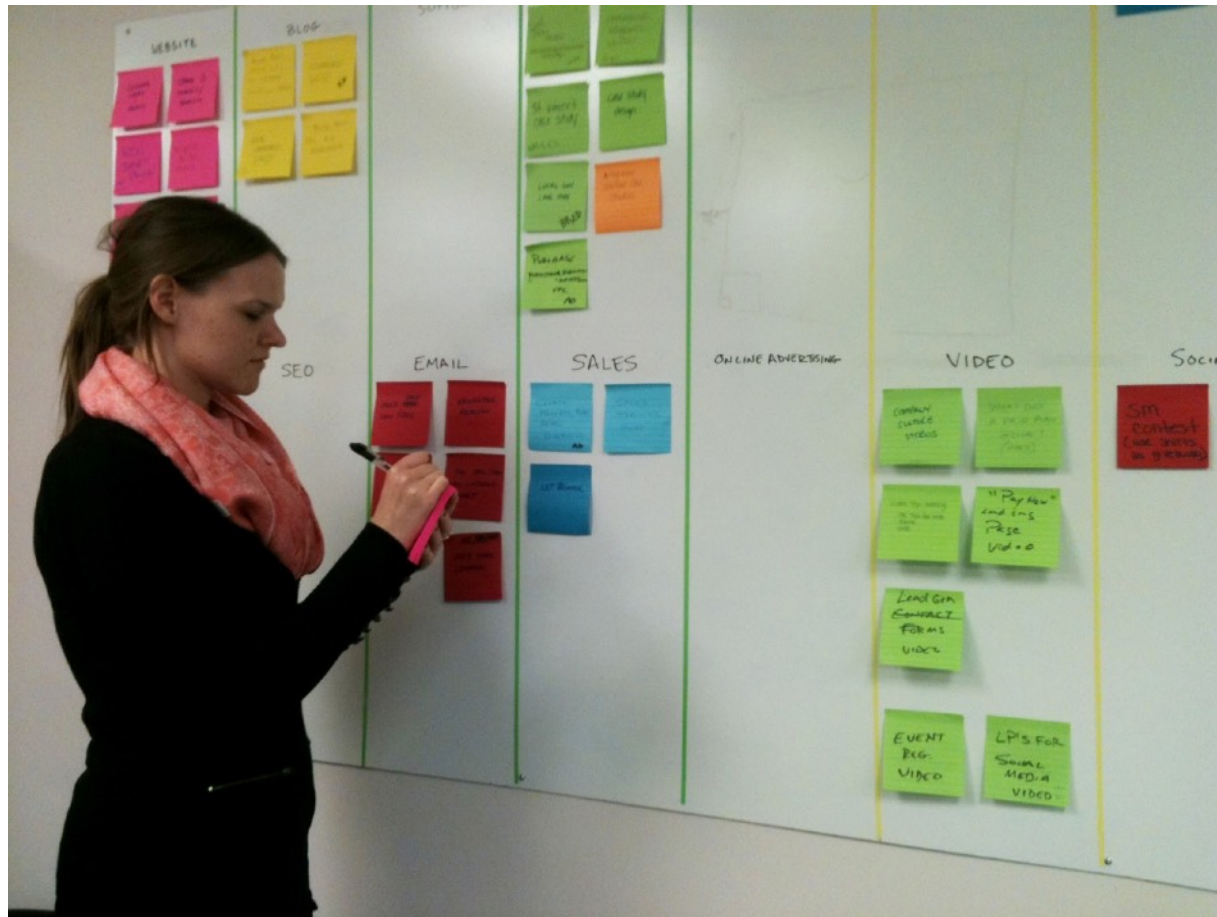

Wallboard

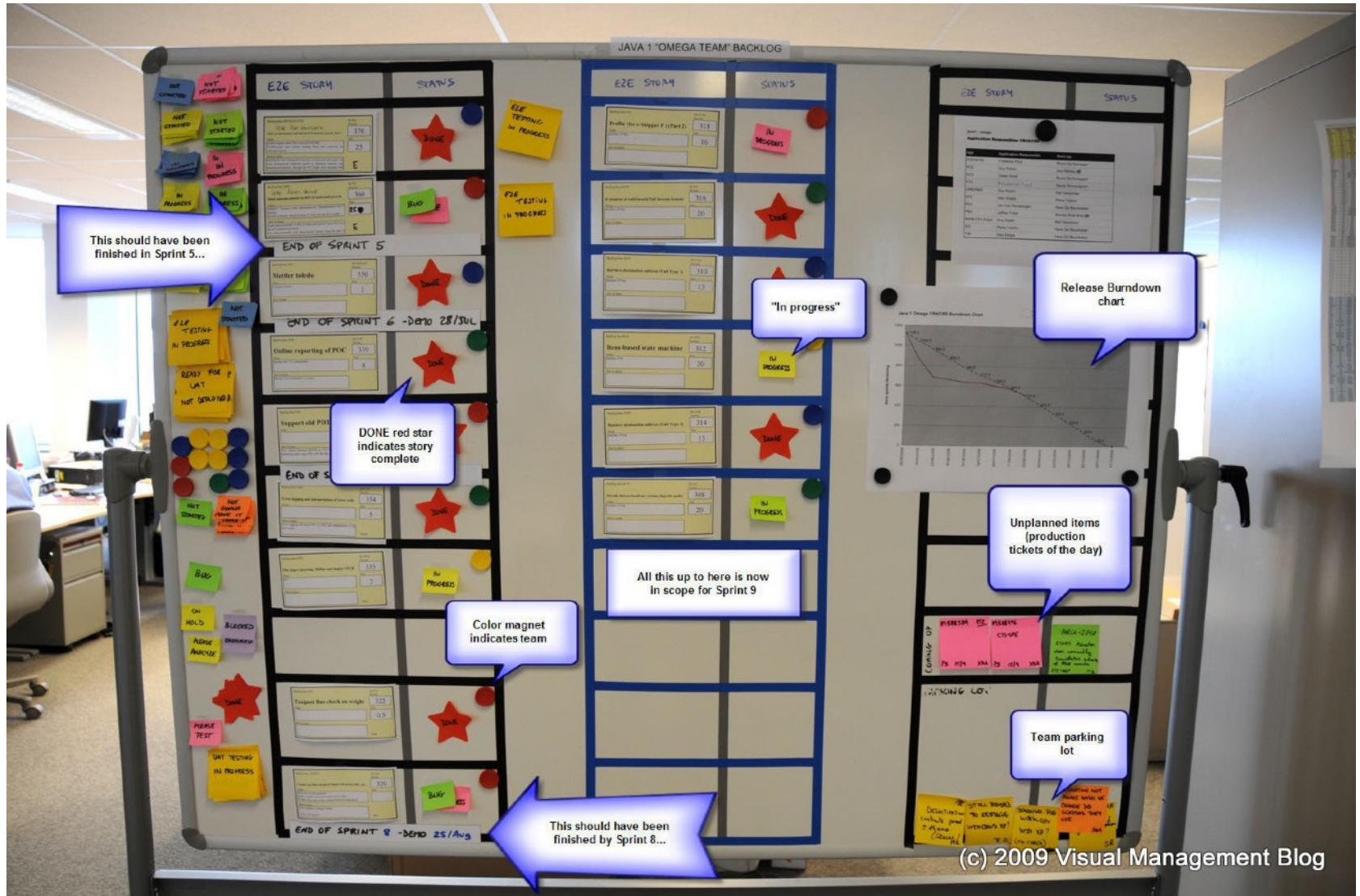

LEGO Bit planner

OCTOBER



NOVEMBER



DECEMBER

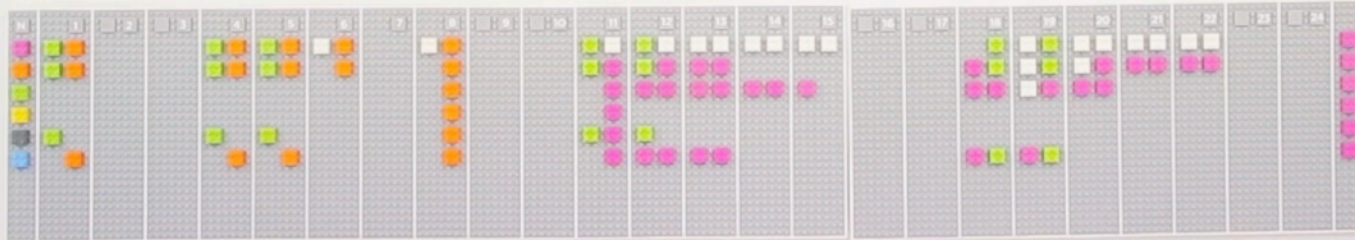

Scrum software

The screenshot displays the JIRA Agile interface for a project named "Angry Nerds". The top navigation bar includes "Dashboards", "Projects", "Issues", "Agile", and "Bonfire". The main content area is divided into three sections:

- Angry Sprint:** Shows a progress bar and a list of 8 issues. The issues are:
 - NERD-1: As a Front-Ender I would like to stop supporting IE6 so I can enjoy my life (Estimate: 3)
 - NERD-2: As a Hacker I would like more Red Bull so I can work all night (Estimate: 8)
 - NERD-3: As the Dev Manager I would like to look busy so I can keep my job (Estimate: 0)
 - NERD-4: As an Outsourcerer I want to get paid for working in my pyjamas (Estimate: 20)
 - NERD-5: As an Agilista I want to play buzzword bingo so I can ban (Estimate: 0)
 - NERD-6: As the Founder I want to have the last say so I can get my way (Estimate: 13)
 - NERD-8: As a Bug I want to fly in the face of progress (Estimate: 0)
 - NERD-7: As a Bug I want to make like hard for the Angry Nerds (Estimate: 0)
- Upcoming Sprint 1:** Shows a list of 5 issues:
 - NERD-9: As a Bug I want to be like The Beatles so I can be fab (Estimate: 0)
 - NERD-12: As a Front-Ender I would like to stop supporting IE7 so I can enjoy my life (Estimate: 5)
 - NERD-13: As a Hacker I would like more pizza and beer (Estimate: 3)
 - NERD-20: As a Hacker I would like to hack the mainframe and enter the Matrix (Estimate: 13)
 - NERD-14: As a Dev Manager I want make everyone log time so I can make nice charts (Estimate: 8)
- Upcoming Sprint 2:** Shows a list of 3 issues:
 - NERD-15: As an Outsourcerer I want to work more hours and get less done (Estimate: 3)
 - NERD-16: As an Agilista I want to be lean to make the green, quicker (Estimate: 1)
 - NERD-17: As an Agilista I want to iterate on the rate so I can rate the iteration (Estimate: 5)

The right-hand panel provides a detailed view of issue "NERD-4":

- Title:** As an Outsourcerer I want to get paid for working in my pyjamas
- Estimate:** 20
- Status:** Not Started (0/1 Completed)
- Session:** Confirm they are in pyjamas (Created)
- Actions:** Create Session

Scrum software

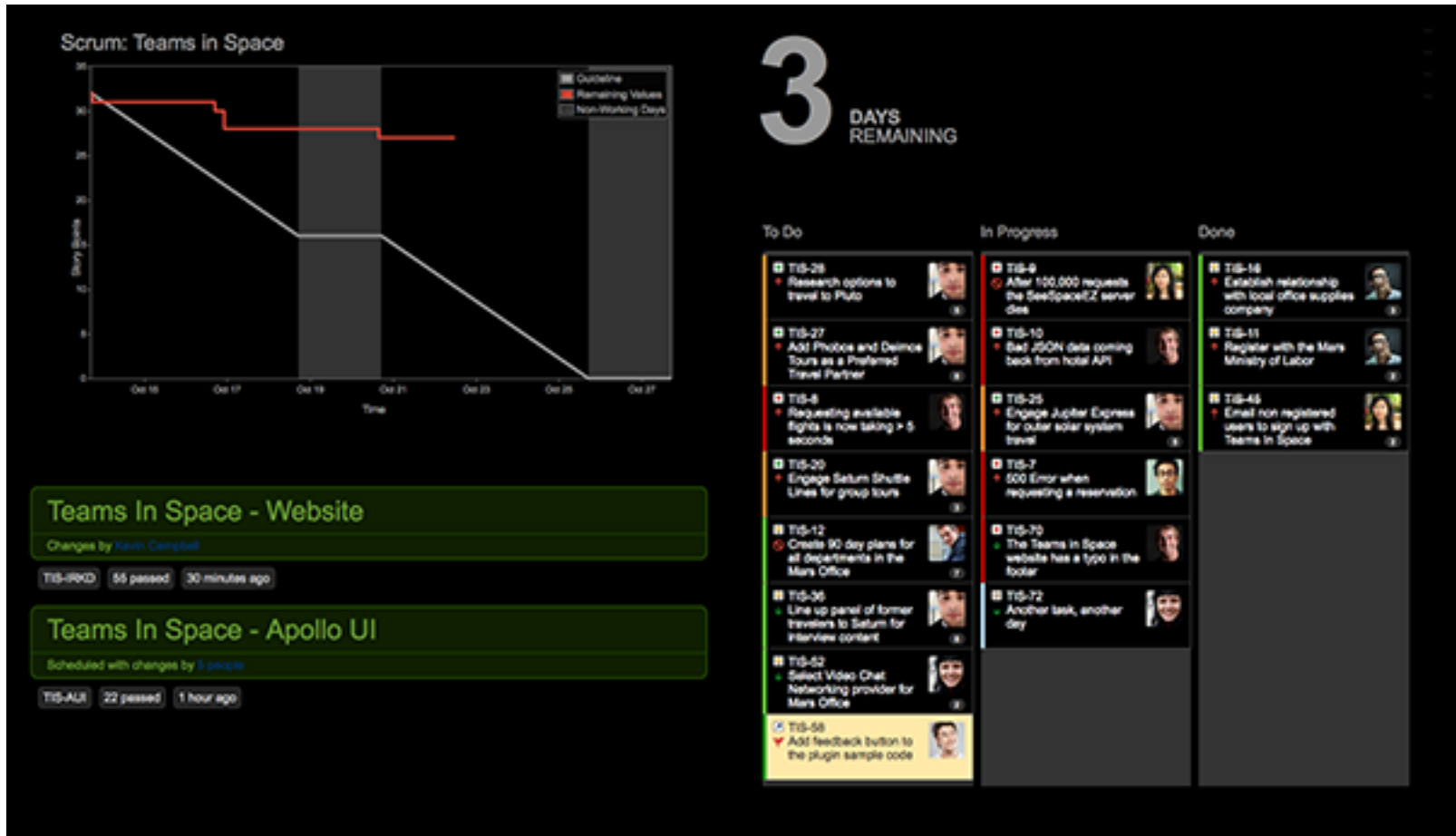

Conclusion

Collaboration in software development

- Is necessary for large projects

- Is not obvious:

 - Technical, organizational and social aspects

Version control supports asynchronous collaboration

- Explicit synchronization between versions

- Branching: split work among developers

Conclusion

Continuous integration

Improves safety and efficiency

Agile method

Organizes a development team

Proposes an adaptative process
to unpredictable requirements

References

Version control

<http://nvie.com/posts/a-successful-git-branching-model/>

<http://www-igm.univ-mlv.fr/~dr/XPOSE2010/gestiondeversiondecentralisee/dvcs-svn.html>

<http://www.infres.enst.fr/~bellot/java/poly/git.pdf>

<http://fr.openclassrooms.com/informatique/cours/gerez-vos-codes-source-avec-git/qu-est-ce-qu-un-logiciel-de-gestion-de-versions>

Continuous Integration

<http://martinfowler.com/articles/continuousIntegration.html>

Agile Models

<http://agilemanifesto.org>

<http://martinfowler.com/articles/newMethodology.html>

Pair Programming

http://www.versionone.com/Agile101/Pair_Programming.asp

Scrum

<http://scrumreferencecard.com>