

# Conceptual modeling

Michel Beaudouin-Lafon - [mb@lisn.fr](mailto:mb@lisn.fr)

Laboratoire Interdisciplinaire des Sciences du Numérique (LISN)

Ex Situ - <http://ex-situ.lri.fr>

# Interactive system

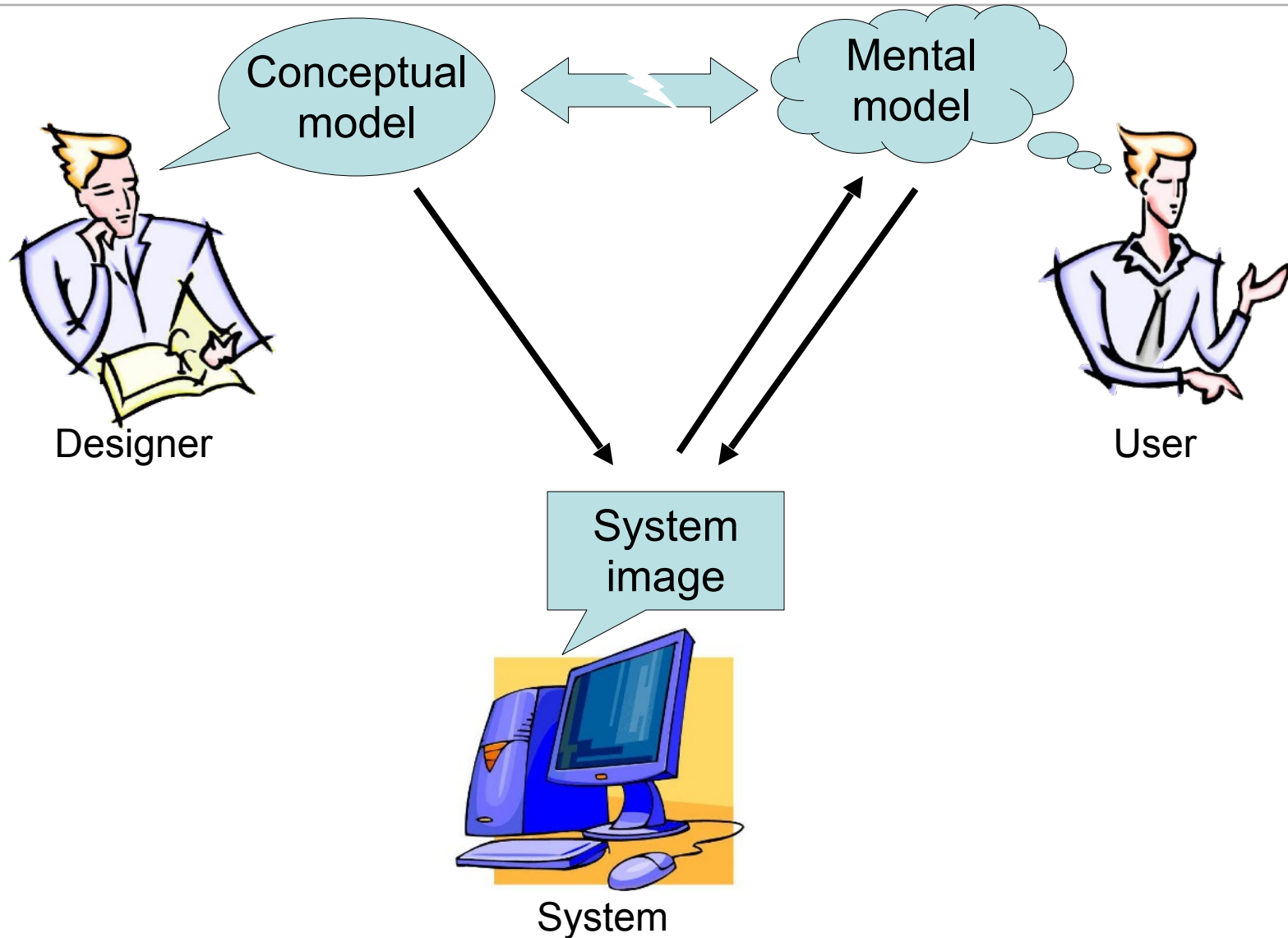

# Conceptual modeling

## Conceptual model

How the designer wants the user to see the system

Must hide technical aspects

Must refer to what the user will use the system for

## System image

What the user sees of the system (including its documentation)

Used by users to create their mental model

## User mental model

Created based on the users' understanding of the system image, their use of the system, what others have told them about the system, etc.

# Conceptual modeling

Correspondence between conceptual model and mental model:

- improved by a proper use of metaphors
- improved by taking advantage of affordances
- improved by following proper *design guidelines*

In case of poor correspondence:

- Manipulation errors
- Frustration
- Lower productivity



# Example

## Confusion over Palm Beach County ballot

**Although the Democrats are listed second in the column on the left, they are the third hole on the ballot.**

**Punching the second hole casts a vote for the Reform Party.**

(REPUBLICAN) GEORGE W. BUSH - PRESIDENT DICK CHENEY - VICE PRESIDENT	3 →	(REFORM) PAT BUCHANAN - PRESIDENT EZOLA FOSTER - VICE PRESIDENT	← 4
(DEMOCRATIC) AL GORE - PRESIDENT JOE LIEBERMAN - VICE PRESIDENT	5 →	(SOCIALIST) DAVID McREYNOLDS - PRESIDENT MARY CAL HOLLIS - VICE PRESIDENT	← 6
(LIBERTARIAN) HARRY BROWNE - PRESIDENT ART OLIVIER - VICE PRESIDENT	7 →	(CONSTITUTION) HOWARD PHILLIPS - PRESIDENT J. CURTIS FRAZIER - VICE PRESIDENT	← 8
(GREEN) RALPH NADER - PRESIDENT WINDA LADUKE - VICE PRESIDENT	9 →	(WORKERS WORLD) MONICA MOOREHEAD - PRESIDENT GLORIA LA RIVA - VICE PRESIDENT	← 10
(SOCIALIST WORKERS) JAMES HARRIS - PRESIDENT MARGARET TROWE - VICE PRESIDENT	11 →	WRITE-IN CANDIDATE To vote for a write in candidate, follow the directions on the long stub of your ballot card.	
(NATURAL LAW) JOHN HAGELIN - PRESIDENT NAT GOLDBABER - VICE PRESIDENT	13 →		

# Example : Fridge

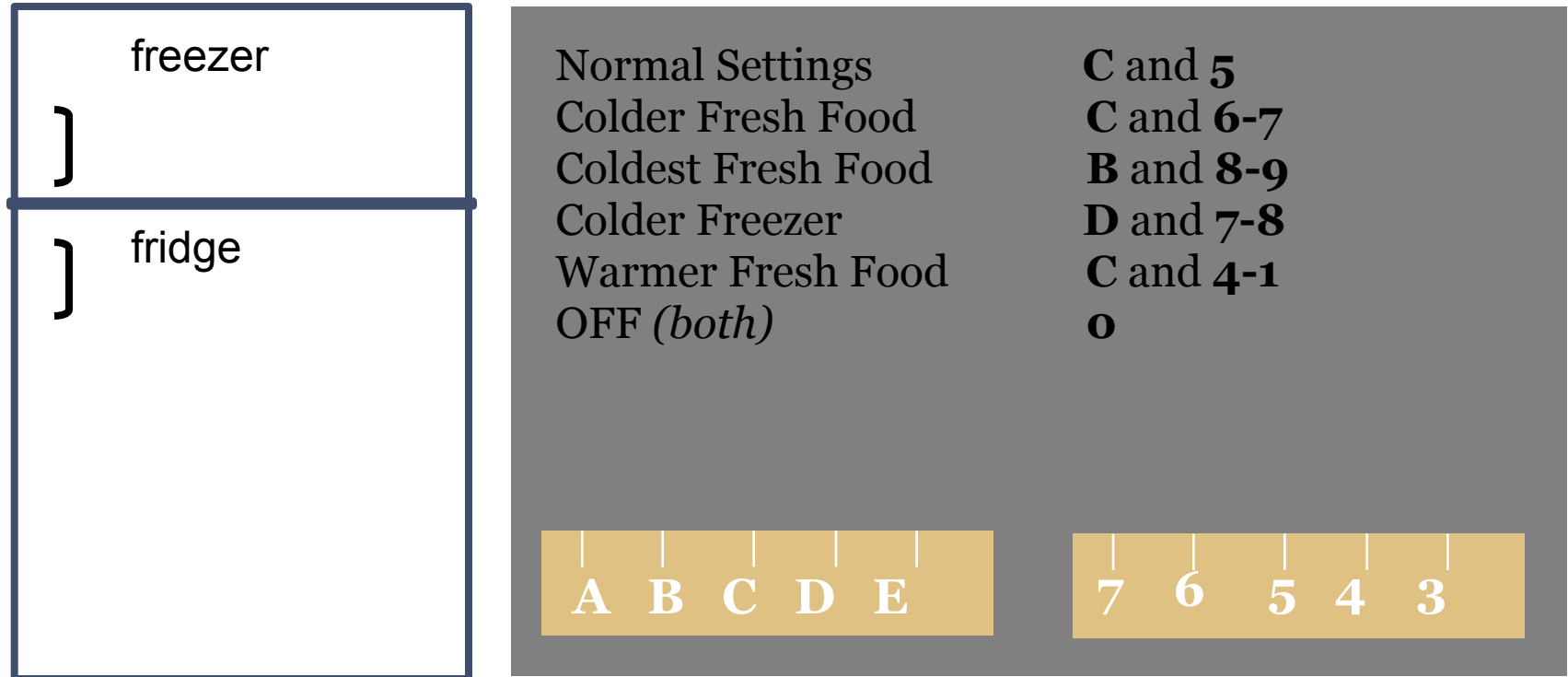

What is your conceptual model?

# A likely mental model

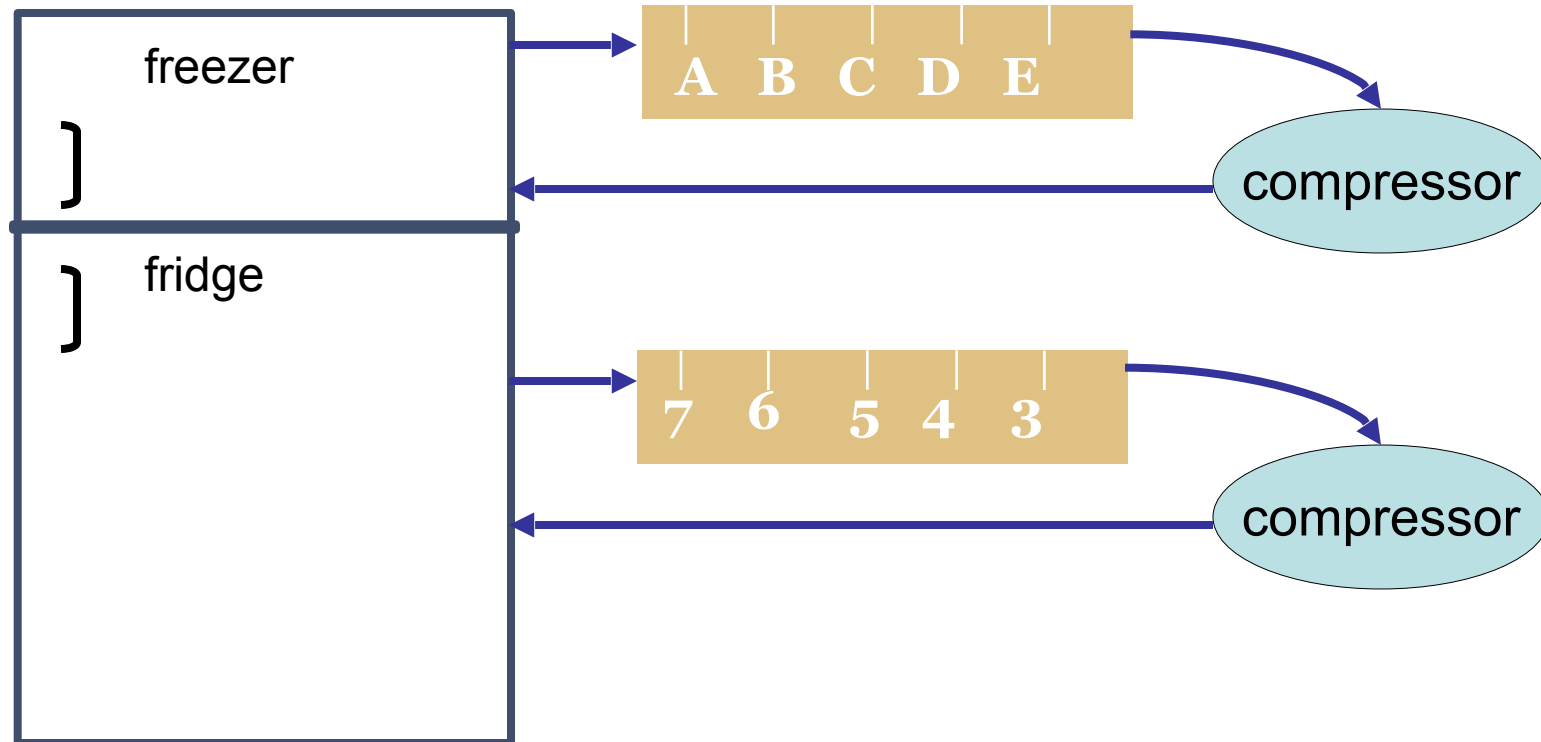

# Real conceptual model

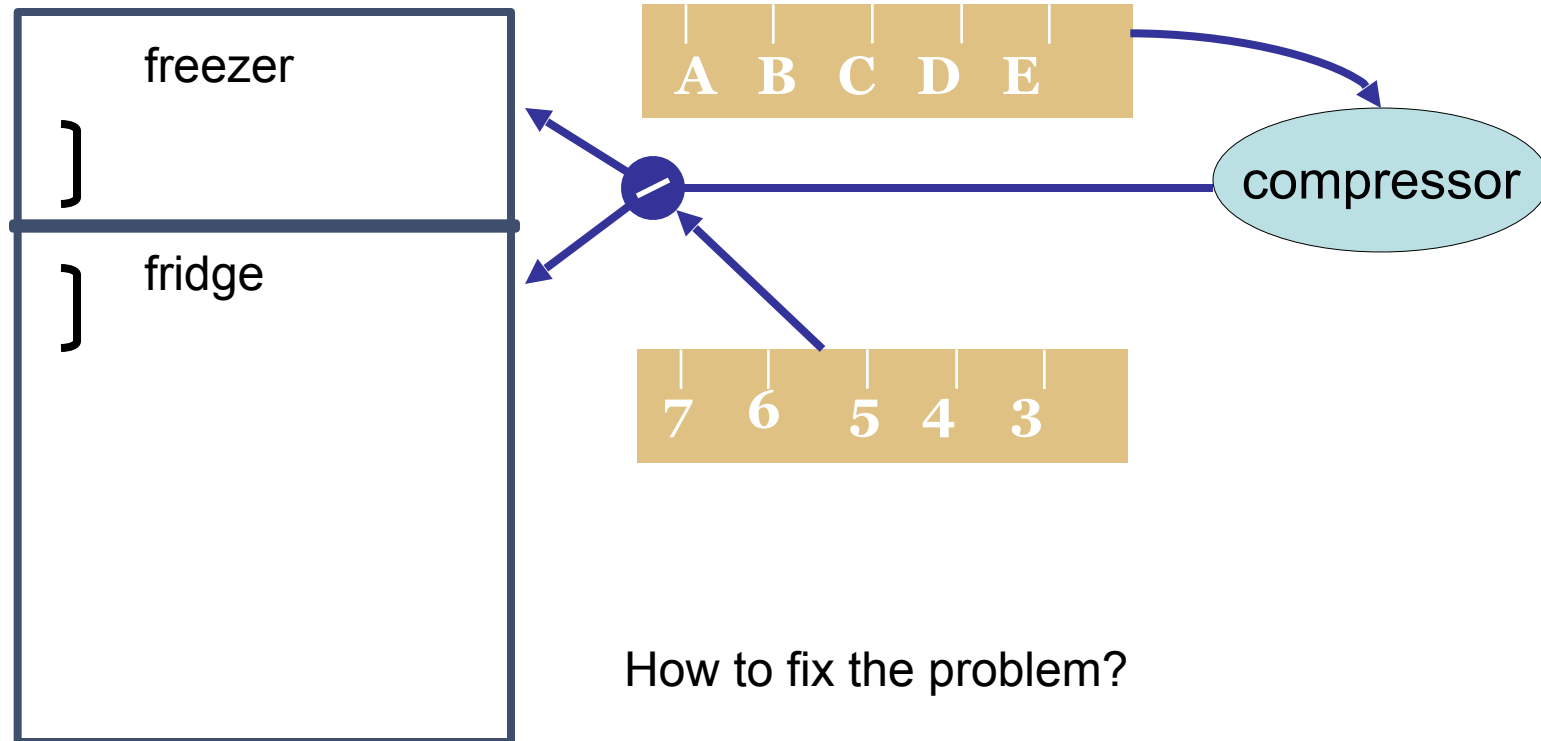

Change the controls so they match what users expect  
Change the controls so they reflect how it really works

# Organizing the conceptual model

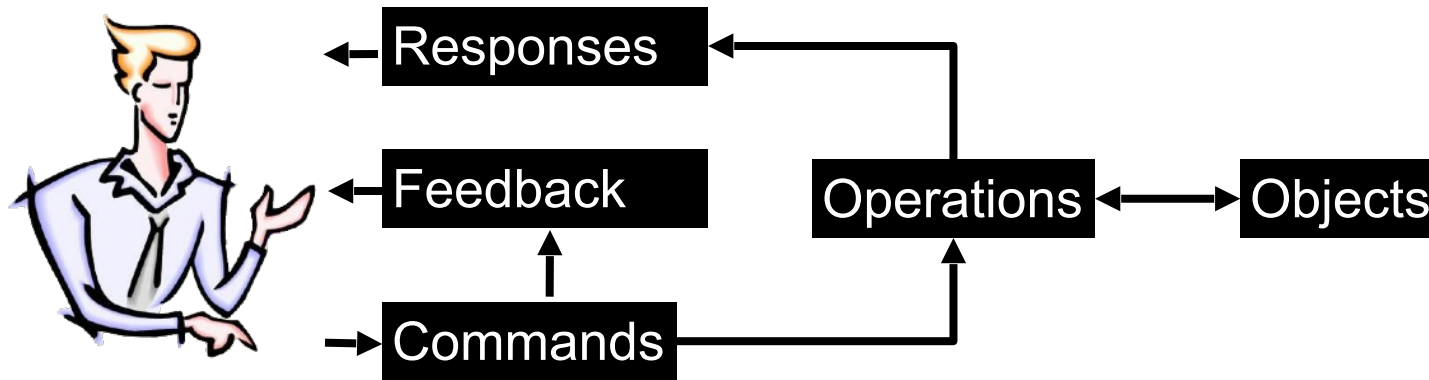

Identify the objects:

What the user wants to manipulate

Identify the operations:

What the user wants to do with the objects

Identify the commands:

How the user can activate the operations

# Interaction tables

Organize the conceptual model into two tables:

Objects	Representations	Properties	Operations
File	Icon (according to file type) + name	Path Type, name, size, ...	Delete Rename ...

Operations	Commands	Feedback	Responses
Delete a file	Drag-and-drop the icon into the trash	The ghost of the icon follows the cursor	The icon disappears and the trash can gets bigger
	Select file and hit the Delete key	Selected icon gets highlighted	The icon moves towards the trash can and disappears

# Beware!

An interface object is not a conceptual object

An interface object is not a conceptual object

An interface object is not a conceptual object

An interface object is not a conceptual object

An interface object is not a conceptual object

A **button** is not a conceptual object

A **menu** is not a conceptual object

A **dialog box** is not a conceptual object

Direct manipulation of (representations of) conceptual objects

VS

Indirect manipulation of these objects through interface objects

# Case studies

Conceptual models of different graphical editors

Pixel-based images (Photoshop)

Vector-based images (Illustrator)

Other case studies (not covered here)

Editor for images described as planar maps

Web browser

File browser

Text editor

Mail reader

...

# Drawing tools

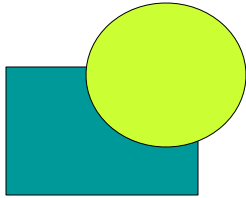

What is this drawing made of?  
How to create this drawing?

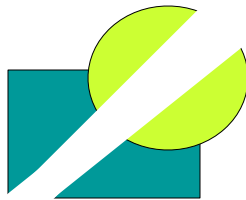

It is a set of pixels  
that can be erased

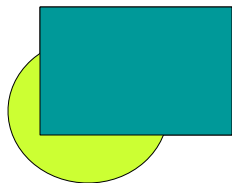

It is a rectangle and a circle  
that can be moved

# Two broad categories

Editing **bitmaps** – images made out of pixels

Basic objects: set of pixels (areas)

Basic operations:

- Define an area

- Apply an operation to the pixels in an area

Editing **vectors** – images made out of geometrical shapes

Basic objects: a stack of vector-based objects

Basic operations:

- Modify the geometry (shape) of an object

- Modify the graphical attributes of an object

- Change the stacking order (2D1/2)

# Editing bitmaps

Operations	Commands	Feedback	Responses
Select an area			
Paint the selected area			

# Editing bitmaps

Operations	Commands	Feedback	Responses
Select an area	Select rectangle tool + Click-and-drag a rectangle	Cursor change  Display ghost rectangle	Area surrounded by “marching ants”
Paint the selected area			

# Editing bitmaps

Operations	Commands	Feedback	Responses
Select an area	Select rectangle tool + Click-and-drag a rectangle	Cursor change  Display ghost rectangle	Area surrounded by “marching ants”
	Select lasso tool + Outline the area	Cursor change  Display ghost outline	Area surrounded by “marching ants”
Paint the selected area			

# Editing bitmaps

Operations	Commands	Feedback	Responses
Select an area	Select rectangle tool + Click-and-drag a rectangle	Cursor change  Display ghost rectangle	Area surrounded by “marching ants”
	Select lasso tool + Outline the area	Cursor change  Display ghost outline	Area surrounded by “marching ants”
Paint the selected area	Select brush tool + Click-and-drag to paint	Cursor change  Display ink	Apply current color to the path of the brush
	Select paint bucket tool + Click the area	Cursor change	Selected area is filled with the current color

# Editing bitmaps

Operations	Commands	Feedback	Responses
Modify the selected area			
Transform the selected area			

# Editing bitmaps

Operations	Commands	Feedback	Responses
Modify the selected area	Command “Invert” in the “Selection” menu		Exchanges the selected and non-selected areas
	Command “Extend” in the “Selection” menu		Extends the selection by one pixel
Transform the selected area			

# Editing bitmaps

Operations	Commands	Feedback	Responses
Modify the selected area	Command “Invert” in the “Selection” menu		Exchanges the selected and non-selected areas
	Command “Extend” in the “Selection” menu		Extends the selection by one pixel
Transform the selected area	Select an item in the “Filters” menu	Dialog box with parameters of the filter	Apply the filter to the selected area
	etc.	...	...

# Editing bitmaps

Objects	Representations	Properties	Operations
Area			

# Editing bitmaps

Objects	Representations	Properties	Operations
Area	“Marching ants” (blinking outline)	The set of pixels inside the area	Define Modify Fill

# Editing bitmaps

Objects	Representations	Properties	Operations
Area	“Marching ants” (blinking outline)	The set of pixels inside the area	Define Modify Fill
Brush	Cursor shape	Shape Transparency Color	Paint

# Editing bitmaps

Objects	Representations	Properties	Operations
Area	“Marching ants” (blinking outline)	The set of pixels inside the area	Define Modify Fill
Brush	Cursor shape	Shape Transparency Color	Paint
Tool set	Tool palette	List of tools Selected tool	Select tool
etc.	...		

# Vector-based editing

Operations	Commands	Feedback	Responses
Create an object			
Select one or more object			

# Vector-based editing

Operations	Commands	Feedback	Responses
Create an object	Select an object type in the palette +	Cursor change	Creates new shape with current attributes on top of all other
	Click-and-drag	Rubber-band the object shape	
Select one or more object			

# Vector-based editing

Operations	Commands	Feedback	Responses
Create an object	Select an object type in the palette + Click-and-drag	Cursor change  Rubber-band the object shape	Creates new shape with current attributes on top of all other
	Select the pencil+ Click-and-drag each control point	Cursor change  Each click-and-drag defines a point and its tangent	Creates new shape with current attributes on top of all other shapes
Select one or more object			

# Vector-based editing

Operations	Commands	Feedback	Responses
Create an object	Select an object type in the palette + Click-and-drag	Cursor change  Rubber-band the object shape	Creates new shape with current attributes on top of all other
	Select the pencil+ Click-and-drag each control point	Cursor change  Each click-and-drag defines a point and its tangent	Creates new shape with current attributes on top of all other shapes
Select one or more object	Click an object		Adds handles to the selected object
	Click on the background+ drag	Ghost of the selection rectangle	Adds handles to the selected objects

# Vector-based editing

Operations	Commands	Feedback	Responses
Modify the geometry of an object			
Modify the attributes of an object			
Change the stacking order			

# Vector-based editing

Operations	Commands	Feedback	Responses
Modify the geometry of an object	Select object + click-and-drag the handles	Ghost of the reshaped object	Changes the shape of the object
Modify the attributes of an object			
Change the stacking order			

# Vector-based editing

Operations	Commands	Feedback	Responses
Modify the geometry of an object	Select object + click-and-drag the handles	Ghost of the reshaped object	Changes the shape of the object
Modify the attributes of an object	Click object + Use the attributes inspector	Values of the attributes are displayed in inspector	Applies new values to the object
Change the stacking order			

# Vector-based editing

Operations	Commands	Feedback	Responses
Modify the geometry of an object	Select object + click-and-drag the handles	Ghost of the reshaped object	Changes the shape of the object
Modify the attributes of an object	Click object + Use the attributes inspector	Values of the attributes are displayed in inspector	Applies new values to the object
Change the stacking order	Click object + select command “bring to front” or “send to back”		Puts the object on top or below all others
	Click object + select command “Order” + slider	The stacking of the object changes according to the slider	Changes the stacking order of the object

# Vector-based editing

Objects	Representations	Properties	Operations
Vector-based shapes			

# Vector-based editing

Objects	Representations	Properties	Operations
Vector-based shapes	Graphical shape	Geometry Graphical attributes	Create Modify Change attributes

# Vector-based editing

Objects	Representations	Properties	Operations
Vector-based shapes	Graphical shape	Geometry Graphical attributes	Create Modify Change attributes
Style	Attribute inspector	Background color Foreground color Thickness Transparency	Change attribute value

# Vector-based editing

Objects	Representations	Properties	Operations
Vector-based shapes	Graphical shape	Geometry Graphical attributes	Create Modify Change attributes
Style	Attribute inspector	Background color Foreground color Thickness Transparency	Change attribute value
Tool set	Tool palette	List of tools Selected tool	Select
etc.	...		

# Some rules

Group commands by category

- Manage the workspace

- Global editing (layout of objects, ...)

- Local editing (individual object)

- etc.

Verify completeness

- Same operations in both tables

- Each property should be visible and editable

Verify consistency

- Similar interactions have similar effects

# Evaluating a conceptual model

## Using *scenarios* and *storyboards*

Describe realistic sequences of interaction

Verify that they are covered by the model

## Using *walkthroughs*

Verify (and have others verify) the criteria described in the previous slides

## Using *prototypes*

Implement some of the techniques to test and refine them

# Conclusion

The conceptual model is at the heart of an interactive system

Conceptual modeling is a creative activity

One cannot simply apply rules

User-centered design

Analyse interaction from the point of view of the user

Participatory design

Involve users along the design process to understand their needs, validate design choices, and take advantage of their ideas and suggestions